











LEGEND

	STRAINER
	STOP VALVE
	CHECK VALVE
	CONTROL VALVE
	RELIEF VALVE
	DRAIN VALVE
	UNION
	PRESSURE GAUGE
	STEAM TRAP
	VACUUM BREAKER

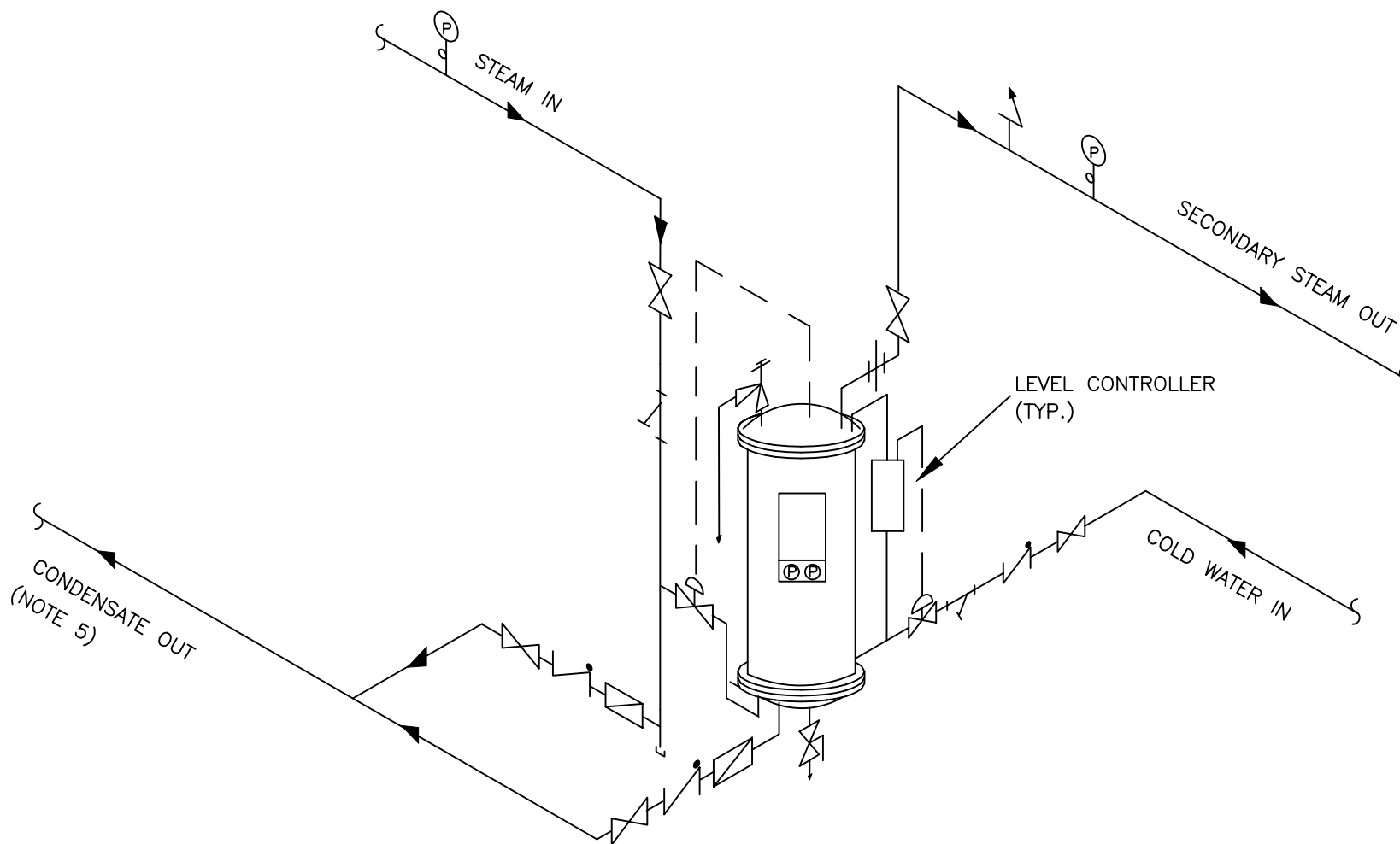

NOTES:

- 1) FOR ACTUAL SIZES AND LOCATIONS OF PIPING AND OTHER CONNECTIONS TO THE HEATER, SEE DIMENSIONAL DRAWING.
- 2) PIPING TO THE UPPER HEATER HEAD SHOULD BE PROVIDED WITH UNIONS OR FLANGES WHICH ARE LOCATED BEYOND THE OUTSIDE DIAMETER OF THE HEAD TO PERMIT REMOVAL OF THE HEAD AND SHELL.
- 3) THE CONTROL VALVE SHOULD BE LOCATED 6" TO 12" ABOVE THE LOWER HEAD FLANGE. THE PIPING BETWEEN THE VALVE AND HEATER CONNECTION SHOULD BE AS SHORT AS POSSIBLE.
- 4) REDUCERS, ON THE WATER INLET SIDE, SHOULD BE LOCATED ADJACENT TO THE HEATER. EXPANSION FITTINGS, ON THE WATER INLET SIDE, SHOULD BE LOCATED AS FAR AS POSSIBLE FROM THE HEATER.
- 5) CONDENSATE RETURN PIPING SHOULD BE ARRANGED TO PERMIT THE CONDENSATE TO DRAIN FREELY, BY GRAVITY, FROM THE LOWER HEATER HEAD.
- 6) DRAIN VALVE SHOULD BE PIPED DIRECTLY TO A FLOOR DRAIN. RELIEF VALVE & OVER-TEMP SOLENOID VALVE SHOULD BE PIPED VERTICALLY TO A HEIGHT 19" ABOVE THE FLOOR.
- 7) COLD WATER SUPPLY PRESSURE MUST BE GREATER THAN SECONDARY STEAM PRESSURE.

AERCO INTERNATIONAL, INC.
NORTHVALE, NJ 07647

SS1B+
STEAM TO STEAM GENERATOR
SINGLE UNIT INSTALLATION

DWN. BY SCD DATE 052499
SCALE NTS
APPD. JES DATE 060299

SD-A-408

REV.
A