

Installation and Maintenance Instructions

Saf-T Vent[®] CI Plus

Double Wall One Inch Air Space AL 29-4C[®] Stainless Steel Special Gas Vent

For Venting Commercial & Industrial Appliances
Condensing Appliances
Category I,II,III,IV Appliances
For Use on Positive, Neutral, and Negative Pressures up to 15" W.C.
Sizes: 5"- 32" Diameters

IMPORTANT: DO NOT INSTALL THIS PRODUCT UNTIL YOU HAVE READ AND FULLY UNDERSTAND THESE INSTALLATION INSTRUCTIONS. FAILURE TO COMPLY WITH THESE INSTRUCTIONS WILL RESULT IN AN IMPROPER INSTALLATION AND WILL VOID ANY STATED WARRANTY.

- Examine all components for possible shipping damage prior to installation.
- Proper joint assembly is essential for a safe installation.
Follow these instructions exactly as written.
Check severeness of joints upon completion of assembly.
- This venting system must be free to expand and contract.
This venting system must be supported in accordance with these instructions.
- Check for unrestricted vent movement through the walls, ceilings, and roof penetrations.
- All joints must be sealed with a factory adhered seal or either GE RTV 106 sealant or Dow Corning #736 sealant.
Allow any field-applied sealant to cure for 24 hours before operating the appliance.
- Different Manufacturers Have Different Joint Systems and Adhesives.
Do Not Mix Pipe, Fittings, or Joining Methods from Different Manufacturers.



Tested and Listed to
UL 1738/ULC S636
by Underwriters Laboratories, Inc



© Copyright 2002 Heat-fab, Inc. Saf-T Vent is a registered trademark of Heat-fab, Inc. AL 29-4C is a registered trademark of ATI Properties, Inc. UL and the UL Mark are registered trademarks of Underwriters Laboratories, Inc.

130 Industrial Boulevard
Turners Falls, MA 01376
Call (800) 772-0739
Fax (413) 863-4803
www.heat-fab.com

TABLE OF CONTENTS

CATEGORY	PAGE
Introduction	3
Pre -Installation Considerations	3
General Installation Considerations	3
Definitions	4
Clearances to Combustibles	5
Horizontal Installations	6
Vertical Installations	7
Condensate Drains	8
Sealant Specification & Coverage	9
Joint Assembly Instructions, Straight Length	10
Joint Assembly Instructions, Rotating Clamp	12
Universal Boiler Adapter	15
Adjustable Section	16
Horizontal Support	17
Rain Cap	18
Guy Support	19
Tall Cone Flashing	24
Pitched Tall Cone Flashing	26
Wall Termination	27
Maintenance	28
Warranty	28

Saf-T Vent CI Plus is a double wall Special Gas Vent that is UL Tested and Listed to the UL 1738 Standard. Saf -T Vent CI Plus is appropriate for use on Category I, II, III and IV gas fired appliances with maximum flue gas temperatures of 550°F. Non categorized condensing appliances and appliances that call for AL29-4C vent systems are also appropriate for Saf-T Vent CI Plus.

Saf-T Vent CI Plus has been tested at 2 1/2 times its positive pressure rating of 15" W.C.

Install in accordance with these instructions and those of the appliance manufacturer. Consult the appliance manufacturer's instructions for the maximum horizontal length of the vent connector, as well as any restriction on total vent height, proper sizing of the vent, common venting considerations and procedures for connecting the vent to the appliance. The installation must conform to applicable NFPA/ANSI standards, as well as local codes. Contact the authority having jurisdiction prior to beginning any work to obtain any required permits.

Pre-Installation Considerations:

- Proper planning prior to installation is essential as to avoid possible contact with concealed plumbing or electrical wiring inside walls, floors or ceilings as well as maintaining proper clearances. Be sure to plan a sufficient number of supports for the entire system that will maintain the required straight-line pitch and hold the system in place. A continuous straight-line pitch of at least 1/4 inch (2 degrees) to the foot on horizontal runs must be maintained in order to properly rid the system of the corrosive condensate.

General Installation Requirements:

- The appliance manufacturer's instructions take precedence over this document.
- Failure to conform to any of these requirements may violate local, state, national or international codes as well as create conditions which may cause catastrophic property damage or personal injury. Failure to conform to any of these requirements will also void any warranties, stated or implied.
- Saf-T Vent CI Plus vent sections, or other Saf-T Vent products, *must* be used throughout the entire length of the system. Alternatives such as galvanized pipe, PVC, nonmetallic pipe, prefabricated chimney, field-fabricated vents or Type B vent sections must not be used. Do not mix pipes, fittings, or joining methods from different manufacturers.
- If called for by the appliance manufacturer's instructions, a drain fitting must be located as close as possible to the appliance flue outlet.
- All joints must be sealed with a factory adhered seal or either GE RTV 106 sealant or Dow Corning #736 sealant. Allow any field-applied sealant to cure for 24 hours before operating the appliance.
- More than one appliance may not be interconnected to any part of the venting system, unless specifically allowed by each of the appliance manufacturers' instructions. Under *no* circumstances should a natural draft appliance be interconnected with a forced draft appliance. All connected appliances must be all natural draft or all forced draft. When venting multiple forced draft appliances, precautions must be taken to prevent back flow of draft.
- Any penetrations of ceilings, floors, or walls must be properly fire-stopped.
- Whenever gas-burning equipment is installed in the same space where halogenated substances may exist (refrigerants, solvents, bleaches, salts, etc.), clean outside air must be utilized for combustion.
- The vent system shall not be routed into, through or within any other actively used vent or chimney.

Definitions:

AL 29-4C - A superferritic stainless steel alloy designed by Allegheny Ludlum for extreme resistance to chloride ion pitting, crevice corrosion and stress corrosion cracking. Equivalent material made by other manufacturers may be identified by the UNS designator S44735.

Category I Appliance - An appliance which operates with a non-positive vent static pressure and with a vent gas temperature that avoids excessive condensate production in the appliance.

Category II Appliance - An appliance which operates with a nonpositive vent static pressure and with a vent gas temperature that may cause excessive condensate production in the appliance.

Category III Appliance - An appliance that operates with a positive vent static pressure and with a vent gas temperature that avoids excessive condensate production in the appliance.

Category IV Appliance - An appliance that operates with a positive vent static pressure and with a vent gas temperature that may cause excessive condensate production in the appliance.

Combustible Material - Any material made of or surfaced with wood, compressed paper, plant fibers, or other materials that are capable of being ignited or burned. Such material shall be considered combustible even though it is flame-proofed, fire-retardant treated, or plastered. (Source: NFPA54/ANSI Z223.1-1999.)

Condensate - The liquid that separates from the vent gases due to a reduction in temperature or increase in pressure.

Condensing Type Appliance - Any Category II or IV appliance. During start-up, some Category III appliances may also produce condensate in the vent.

Non-Combustible Material - Any material that is not capable of being ignited and burned, such material consisting entirely of, or of a combination of, steel, iron, brick, tile, concrete, slate, asbestos, glass, and plaster. (Source: NFPA54/ANSI Z223.1-1999).

Special Gas Vent - Gas vents for venting listed Category II, III, and IV, gas-burning appliances.

UL 1738 - A standard issued by Underwriters Laboratories that covers the requirements for venting systems intended for use on Category II, III, or IV gas-burning appliances.

Vent Connector - The vent or pipe which connects a fuel-gas burning appliance to a vent or chimney.

Clearances to Combustibles:

DIAMETER	CLEARANCE TO COMBUSTIBLE MATERIAL	MAXIMUM FLUE GAS TEMP. (°F)	ORIENTATION	ENCLOSURE
5" - 24"	1"	550	Vertical	Fully enclosed by combustible material on all sides
26" - 32"	2"			
5" - 32"	Not Allowed	550	Horizontal	Fully enclosed by combustible material on all sides
5" - 8"	1"	550	Horizontal	Enclosed on a maximum of 2 sides (ceiling & sidewall)
9" - 12"	2"			
14"	3"			
16" - 20"	4"			
22" - 24"	5"			
26" - 32"	6"			
5" - 32"	0"	550	Any	Noncombustible material

- The allowed clearances may differ by the appliance manufacturer. The appliance manufacturer's instructions and applicable local codes take precedence over this document.
- Refer to the Definitions section of this document for important descriptions of combustible and noncombustible material.
- For venting system that extend through any zone above that on which the connected appliance is located (except for one and two family dwellings), the vent system shall be enclosed with an enclosure having a fire resistance rating equal to or greater than that of the floor or roof assemblies through which it passes.
- Design any enclosure to permit inspection of the system.
- Do not place any type of insulation in any required clearance spaces surrounding the vent system.

Horizontal Installation Requirements:

1. The horizontal vent connector must slope **upward** toward the termination at least 1/4 inch per foot and be installed so that all condensate runs back toward the appliance and is not retained in any part of the venting system. **EXCEPTION:** If the system is connected to positive pressure (Category III or IV) appliances only, terminates with a horizontal termination, and has no provision for draining condensation and/or rain water; then the vent must pitch **downward** toward the termination. This pitch must also be at least 1/4 inch per foot (2 degrees).
2. The vent system must terminate with one of the Saf-T Vent terminations or other terminations as specified or provided by the appliance manufacturer, or approved mechanical vent devices.
3. The Termination Location:
 - (a) The vent shall terminate at least 3 feet above any forced air inlet located within 10 feet.
 - (b) The vent shall terminate at least 4 feet below, 4 feet horizontally from or 1 foot above **AND** 2 feet horizontally from any door, window or gravity air inlet into any building. Exception: Direct Vent appliances may be listed for alternate spacing.
 - (c) The vent termination shall be at least 12 inches above grade or, in geographical areas where snow accumulates, at least 12 inches above the anticipated snow line.
 - (d) Through-the-wall vents for Category II and IV appliances and noncategorized condensing appliances shall not terminate over a public walkway or an area where condensate or vapors could create a nuisance or hazard or could be detrimental to the operation of regulators, relief valves or other equipment. In colder climates where ice buildup is likely to occur, Heat-fab, Inc. will **NOT** be held liable for any personal injury or property damage due to any formation of ice.
 - (e) The vent termination shall also be at least 8 feet horizontally from any combustion air intake, located above it.
 - (f) Horizontal supports are required for every 6 feet of horizontal run and after every transition from vertical to horizontal.
4. The total continuous distance of the vent system from the appliance flue collar to the termination shall not exceed that specified in the appliance manufacturer's installation instructions. When venting natural draft appliances the termination must be at least 5 feet above the topmost draft hood. Otherwise a Listed mechanical draft inducing device is required.

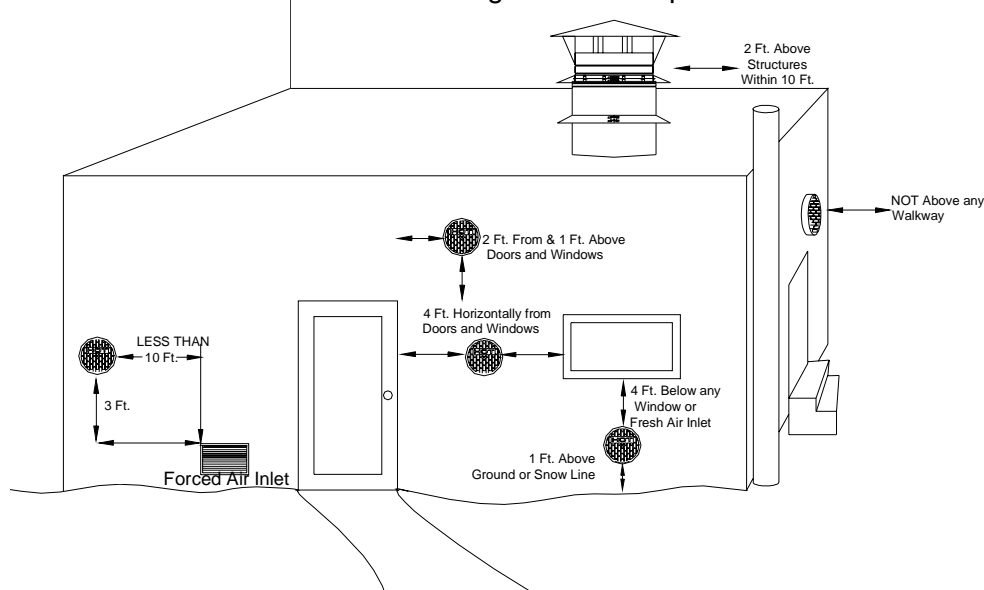

Vertical Installation Requirements:

1. The vent system must terminate at least 3 feet above the roof line and at least 2 feet higher than any portion of the building within 10 feet.
2. When terminated at a height of more than 6 feet the stack must be supported by a Saf-T Vent CI Plus Guy Section.
3. The vent system must terminate with one of the Saf-T Vent Terminations; except:
 - (a) Category I or II appliances (natural draft) must use a Saf-T Vent Rain Cap.
 - (b) Vent systems without provisions for draining rain water must use a Saf-T Vent Rain Cap.
 - (c) Terminations or approved mechanical vent devices specified or provided by the appliance manufacturer are permitted.
4. The total continuous distance of the vent system from the appliance flue collar to the termination shall not exceed that specified in the appliance manufacturer's installation instructions. When venting natural draft appliances the termination must be at least 5 feet above the topmost draft hood. Otherwise a Listed mechanical draft inducing device is required.
5. In general, systems installed in cold climates perform best, and condensation is reduced, when the system is fully enclosed by some part of the building structure. When installing into a combustible square or rectangular vertical chase, the Coupler Band bracket must be positioned into a corner of the chase to provide the 1" clearance as UL listed.
6. In cold climates do not install a condensate drain on the exterior of the building. Doing so may result in dangerous icy conditions on surfaces near the drain and may cause damage to the vent system and/or the building exterior. Heat-fab, Inc. will **NOT** be held liable for any personal injury or property damage due to any formation of ice.
7. Vertical supports are required after every transition to vertical and as specified in the table below. Vertical supports are also required after every offset elbow.

Spacing Between Supports	
Diameters	Spacing
5" thru 12"	20'
14" thru 18"	12'
20" thru 24"	10'
26" thru 32"	6'

Condensate Drains:

When An Internal Condensate Drain Is NOT Part of the Appliance:

- A Saf-T Vent CI Plus In-Line Drain Section or Boot Tee with a separate Drain Tee Cover is strongly recommended. Install this drain fitting as close to the appliance flue collar as possible.
- A condensate drain is required for every 30 feet of horizontal vent and at/near the bottom of a vertical stack.
- Use the In-Line Drain Section for a straight horizontal run. Rotate the fitting so that the drain tube is as vertical as possible.
- Use the Boot Tee at a transition from horizontal to vertical, and attach the Drain Tee Cover to the appropriate leg of the tee.
- A Condensate Drain Tube Kit is available to direct the condensate to an appropriate location, i.e. floor drain or vented sanitary sewer connection. A trap loop must be formed into the drain hose and must be a diameter that is at least four times the appliance's rated stack pressure in inches of water column or 3 inches, whichever is greater. Secure the loop with a cable tie. Prior to final assembly the trap loop must be 'primed' by pouring a small quantity of water into the drain hose.
- Follow all local and national codes and regulations for the draining of acidic condensate.
- In cold climates do not install a condensate drain on the exterior of the building. Doing so may result in dangerous icy conditions on surfaces near the drain and may cause damage to the vent system and/ or the building exterior. Heat-fab, Inc. will **NOT** be held liable for any injury or property damage due to formation of ice.

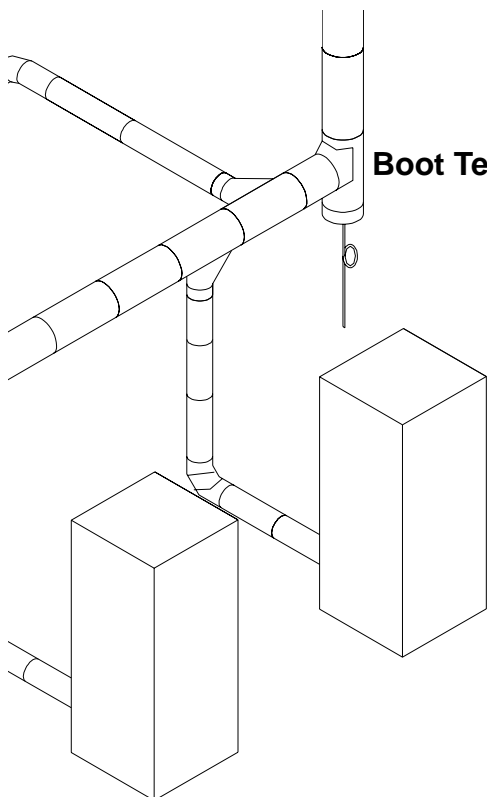
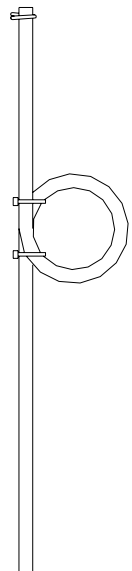

Boot Tee W/Drain Cover and Drain Tube

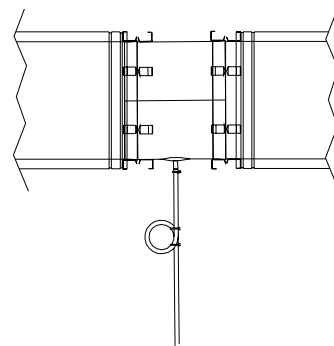

Horizontal In-Line Drain Section

RTV Sealant Specifications:

In order to have a UL Listed system, Saf-T Vent CI Plus parts without a factory adhered seal must be installed with one of the following approved RTV sealants:

Maximum Appliance Flue Gas Temperature	Sealant	Size	Heat-fab Part Number
550° F.	General Electric (GE) RTV 106	2.8 oz tube	7000RTV
	or	10.1 oz cartridge	7000RTVL
	Dow Corning 736		

Approximate Coverage

The table below shows the approximate number of installed joints that can be completed with a container of RTV sealant. These figures are based on a ¼" bead of sealant. Actual coverage may vary.

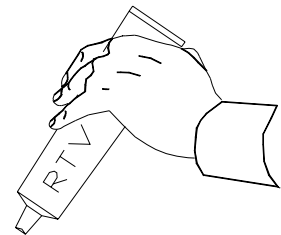

Inner Vent Diameter, Inches	Approximate Number of Joints	
	3 oz Tube	10 oz Cartridge
18	4	14
20	4	13
22	3	12
24	3	11
26	3	10
28	3	9
30	2	9
32	2	8

Note: In planning the RTV required for an installation, please be aware that certain fittings require additional RTV in order to achieve a proper positive-pressure seal. The following types of parts should be counted as 2 joints toward the RTV coverage table:

- Boiler Starters
- Adjustable Sections
- Flue Collar Adapters
- Boot Tees

*Diameters 5" thru 16" are manufactured with a factory adhered seal on the inside of the female end and will **not** need sealant in the joint.

Joint Assembly Instructions for Straight Lengths:

Note: Diameters 5" thru 16" are manufactured with a factory adhered seal on the inside of the female end and will **not** need sealant in the joint.

1. Begin by removing the Locking Strap and Coupler Band from the vent.

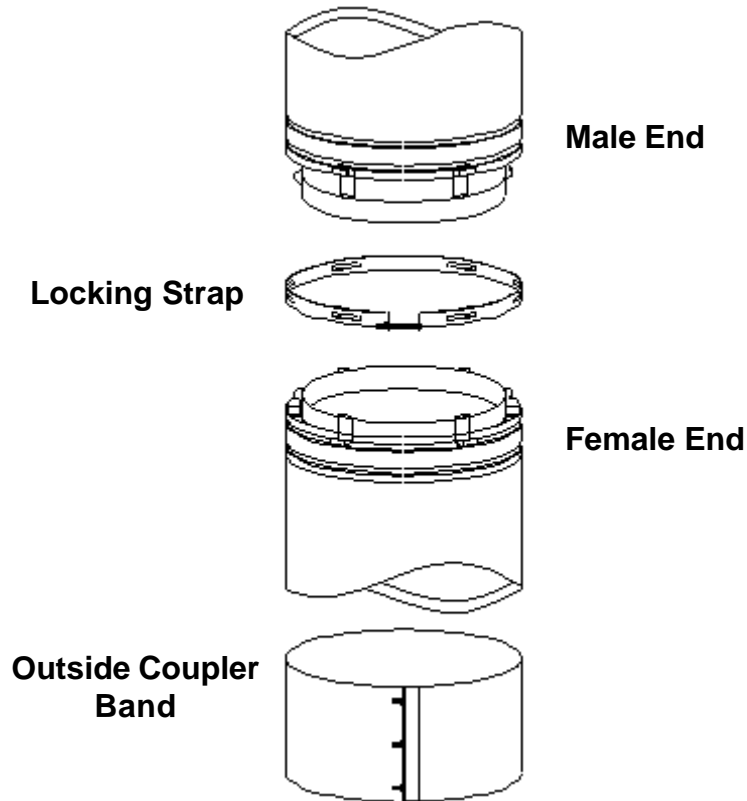

2. Wipe the male and female ends clean with alcohol wipes. On diameter sizes without the gasket, at 3/4" from the edge, apply a 1/4" thick continuous, straight-line bead of high temperature sealant to the inside circumference of the female end. Do not use a zig-zag pattern when applying sealant. Smooth down the bead with a flat instrument or your moistened finger.

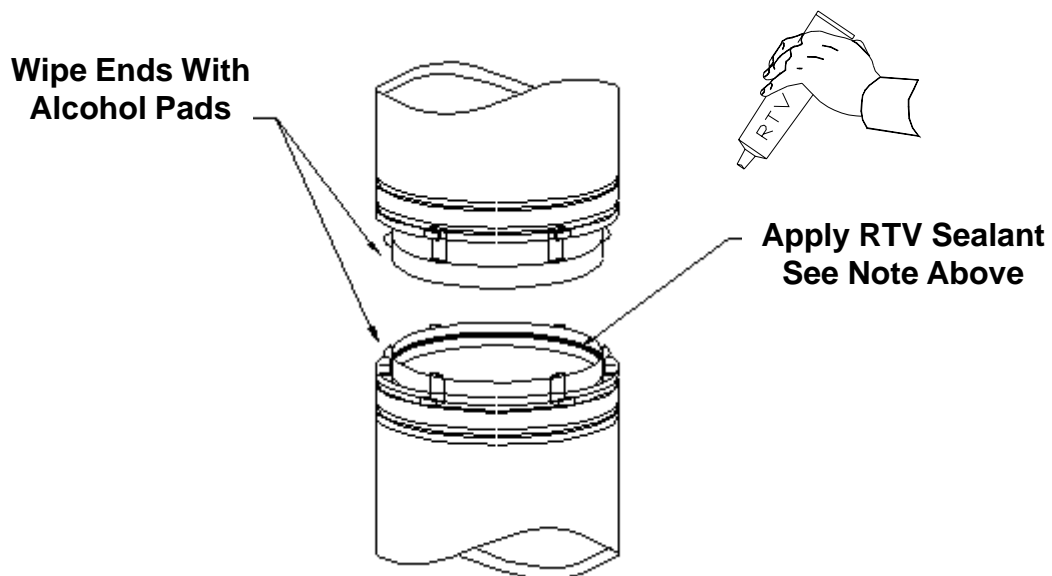

3. Insert the male end into the female end, lining up the Locking Tabs at the same time. If needed, use pliers or vice grips to squeeze together the Tabs so they will accept the slots in the Locking Strap. When assembling elbows and tees, the male end tabs will rotate around the vent to accommodate offsets and direction changes, refer to rotating clamp installation instructions.

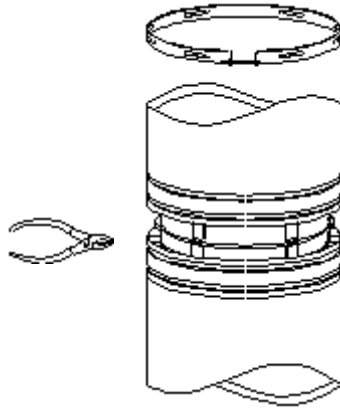

4. Position the Locking Strap slots over the Tabs, making sure each slot encompasses both Tabs. Tighten the Locking Strap with a 7/16" hollow nut driver or deep socket, take caution not to over tighten the clamp causing the vent to collapse.

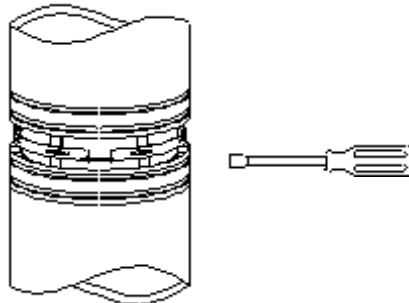

5. Center the Coupler Band around the completed joint and tighten the 7/16" nuts with a hollow nut driver or deep socket. If the assembly must be weather tight, apply a 1/4" bead of sealant to the inside top edge of the Coupler Band approximately 1 inch down from the edge.

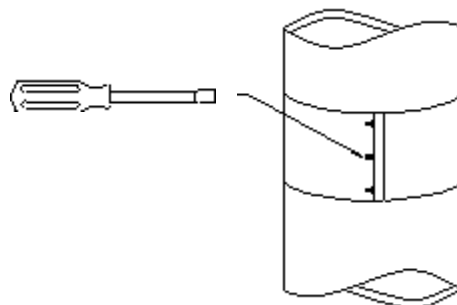

Joint Assembly Instructions for Rotating Clamp:

The rotating clamp allows you to position fittings in the desired flow direction of the breeching layout. Follow these instructions for Elbows, Boot Tees, Increases and In-Line Drains, that all utilize the rotating clamp.

Note: Diameters 5" thru 16" are manufactured with a factory adhered seal on the inside of the female end and will not need sealant in the joint.

1. Begin by removing the Locking Strap and Coupler Band from the vent.

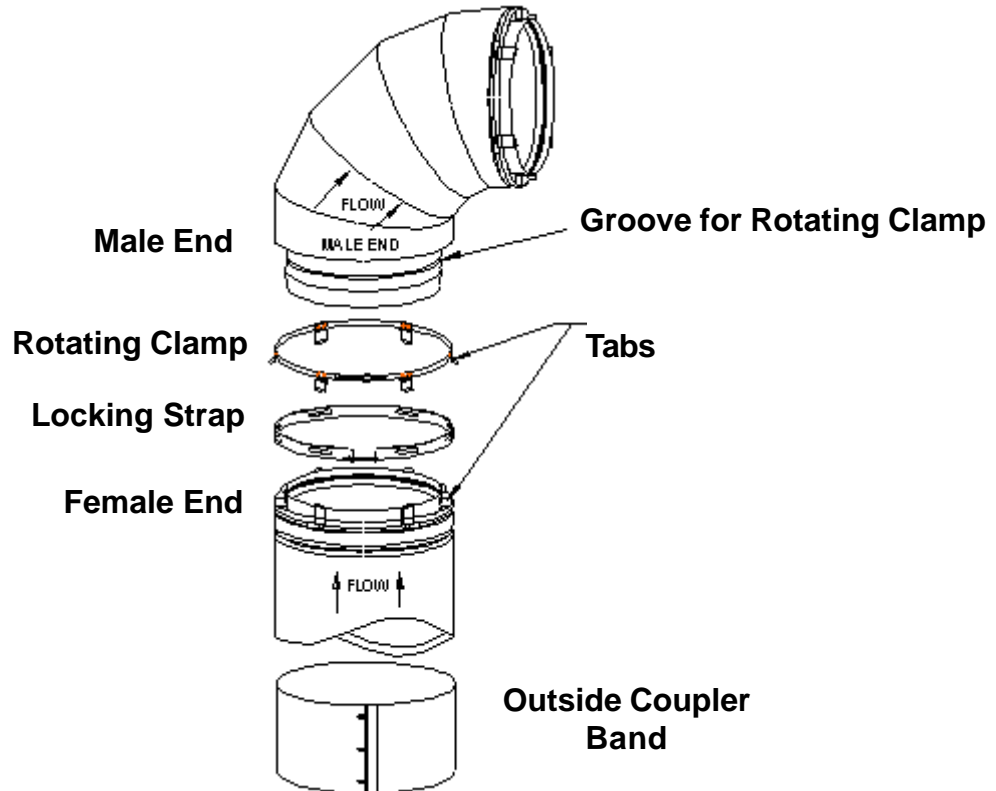

2. Wipe the male and female ends clean with alcohol wipes. On diameter sizes without the gasket, at 3/4" from the edge, apply a 1/4" thick continuous, straight-line bead of high temperature sealant to the inside circumference of the female end. Do not use a zig-zag pattern when applying sealant. Smooth down the bead with a flat instrument or your moistened finger.

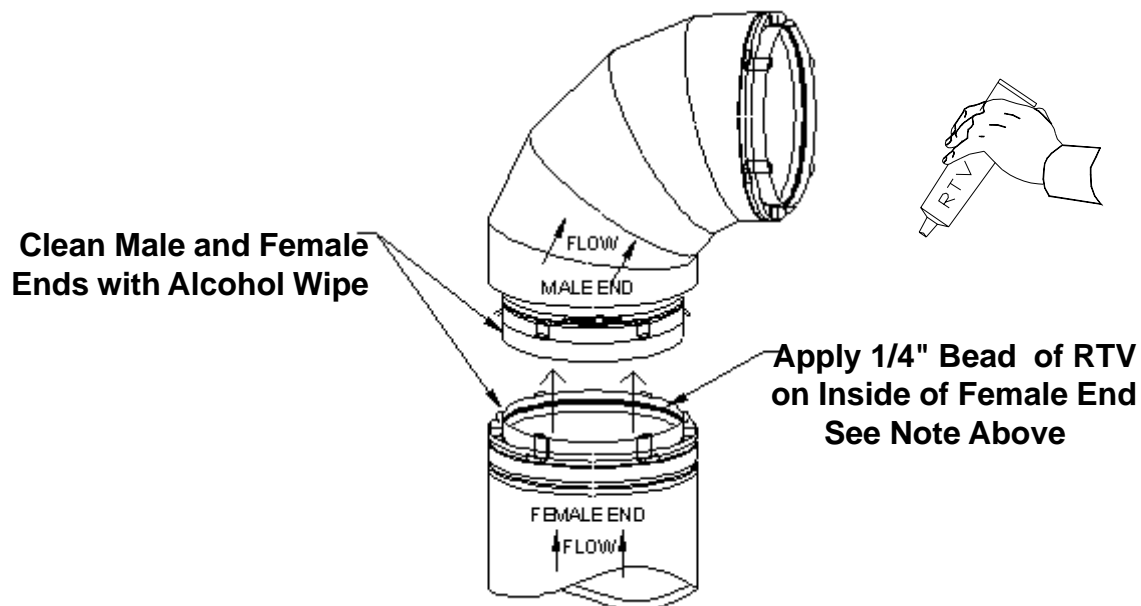

3. Insert the male end into the female end of the preceding vent piece, loosen the rotating clamp on the male end of the fitting with a 5/16" nut driver.

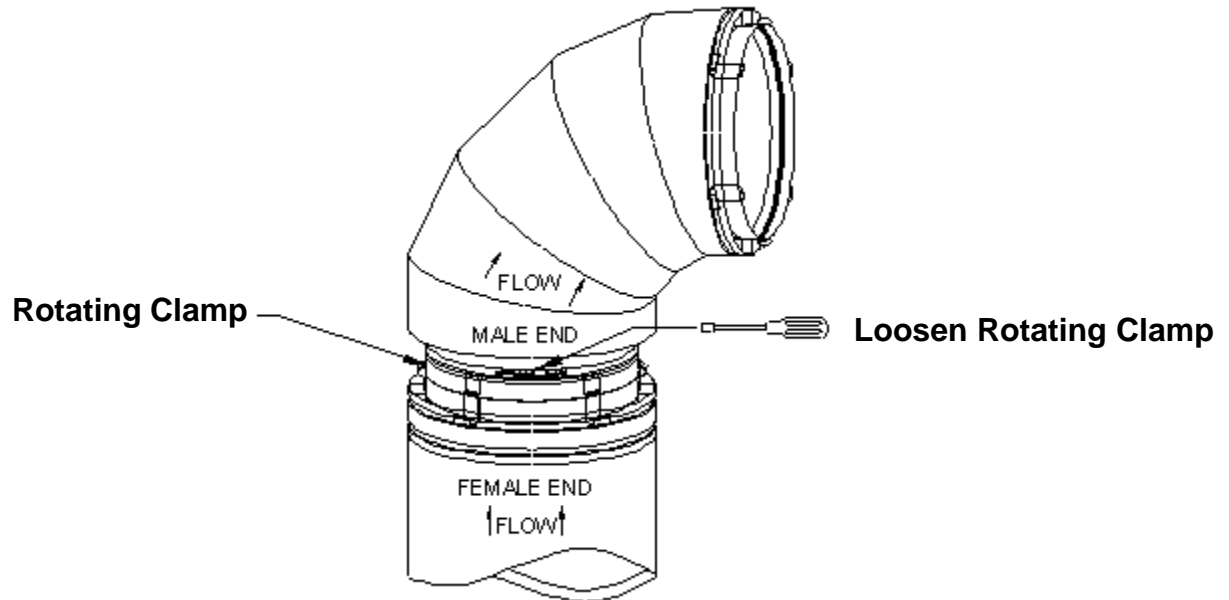

4. Line up the tabs of the rotating clamp with the female end of the preceding vent. Insure the beads on the tabs of the rotating clamp are nested into the groove on the male end. RE-tighten the rotating clamp. If needed use pliers or vice-grips to squeeze together the tabs so they will accept the slots in the locking strap.

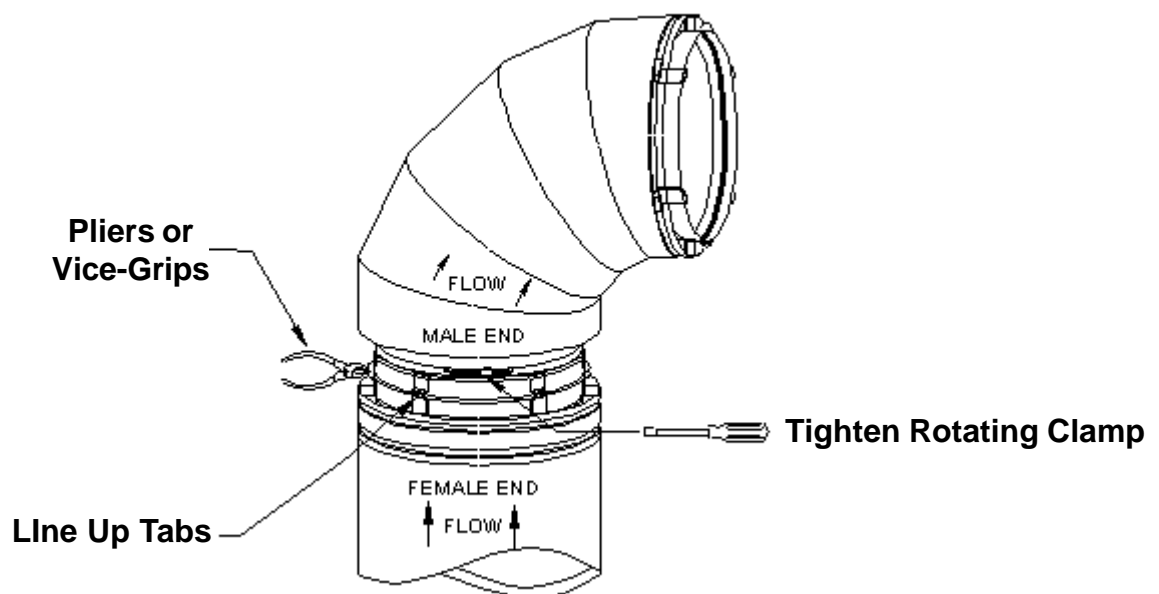

5. Position the Locking Strap slots over the Tabs, making sure each slot encompasses both Tabs. Tighten the Locking Strap with a 7/16" hollow nut driver or deep socket. **CAUTION:** Do not over-tighten the clamp, as it may cause the vent to collapse.

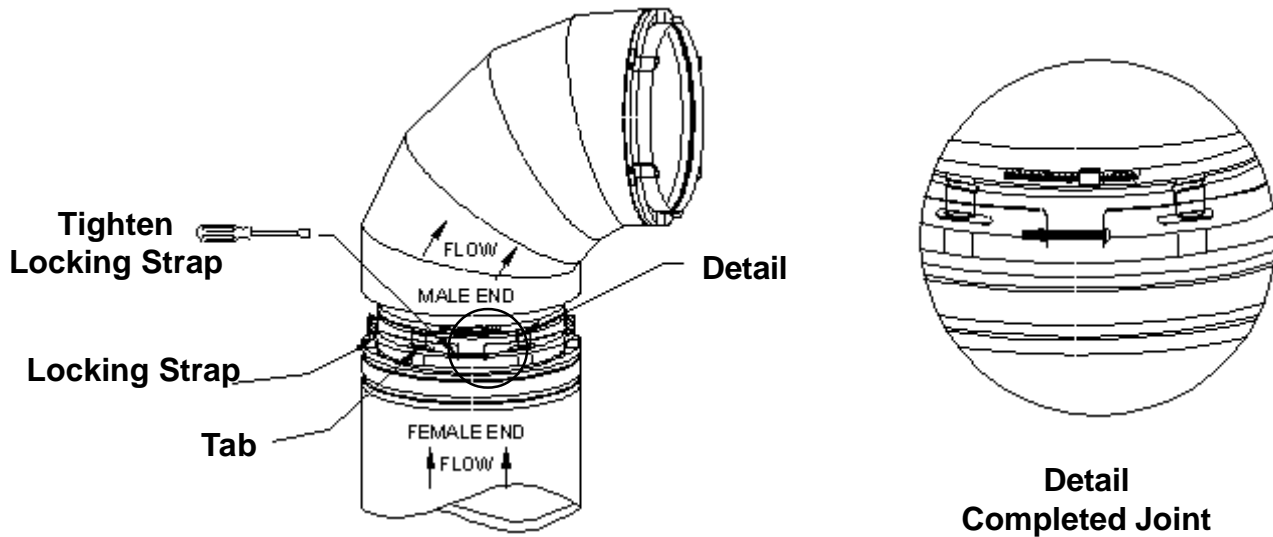

6. Center the Coupler Band around the completed joint and tighten the 7/16" nuts with a hollow nut driver or deep socket. If the assembly must be weather tight, apply a 1/4" bead of sealant to the inside top edge of the Coupler Band approximately 1 inch down from the edge.

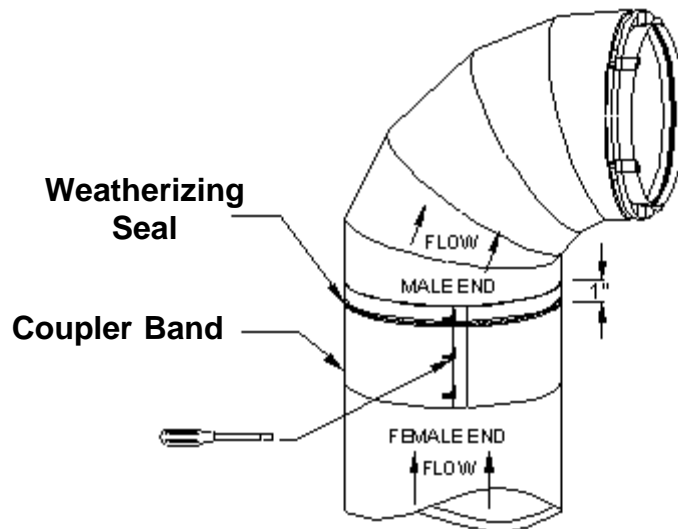

Saf-T Vent CI Plus Universal Boiler Adapter:

The Saf-T Vent CI Plus Universal Boiler Adapter can be used horizontally or vertically to adapt Saf-T Vent CI Plus to nominal diameter flue collars. It can also adapt to flue collars that are slightly out of round.

1. Remove the clamps and coupler band from the adapter, *figure 1*. The adapter must clamp onto the flue collar with no less than 1 inch overlap for proper fit. Mark or scribe the flue collar prior to fitting the adapter, *figure 2*.

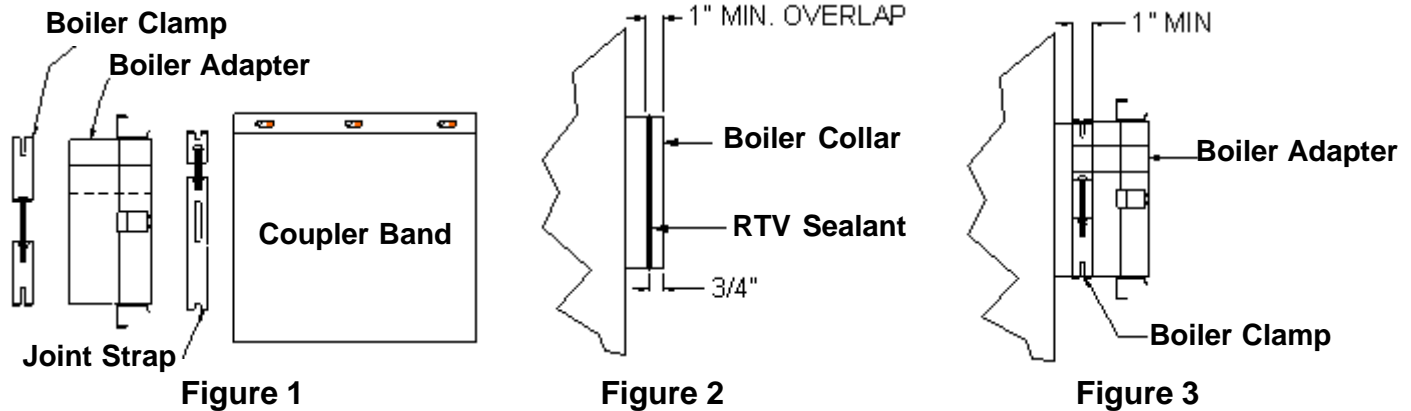

2. All joint surfaces **must** be cleaned with alcohol wipes before applying sealant. Apply a 1/4" thick bead of RTV sealant around the outside of the flue collar approximately 3/4" from the edge. with alcohol. Place the adapter over flue collar lining up the edge of the adapter to the scribe marks, then tighten the boiler clamp snugly, *figure 3*. On horizontal flue collars, the split side of the boiler adapter should be installed along the top of the flue collar.

3. Apply a 1/4" bead of RTV sealant to the inside of the female end of the boiler adapter, 3/4" from the edge, *figure 4*. Make a continuous, straight-line bead, not a zig-zag pattern when applying the sealant.

4. Insert the male end of the first piece of Saf-T Vent CI Plus into the female end of the boiler adapter, lining up the joint tabs, *figure 5*. Install the joint strap over the tabs of both parts. hand tighten the strap with a 7/16" hollow nut driver. **CAUTION:** Overtightening will distort the joint. Re-tighten the boiler clamp around the flue collar. If possible, reach into the vent and apply RTV sealant to all inside seams of the boiler adapter and the first joint. Smooth the sealant with a moistened finger or flat tool, *figure 5*.

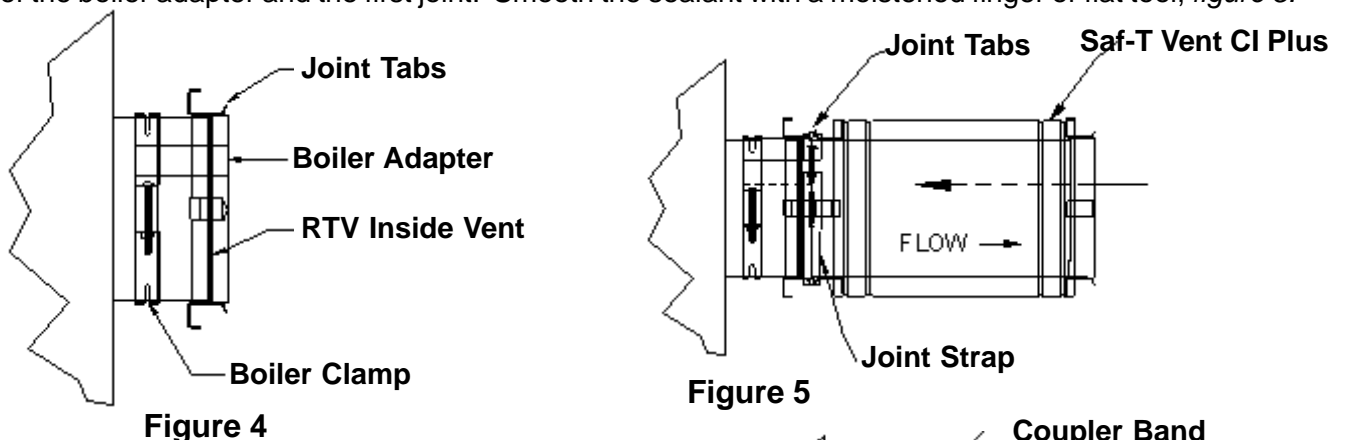

5. Install the coupler band over the boiler adapter to finish installation. *figure 6*.

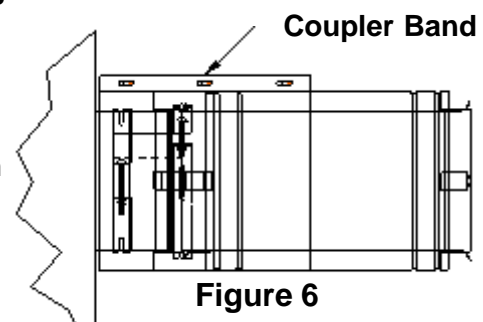

Saf-T Vent CI Plus Adjustable Section:

The Saf-T Vent CI Plus Adjustable Section serves as a variable length between other components when specific lengths cannot be utilized, there is a long, 13 to 20 inch, and a short, 7 to 11 inch, adjustable section. **WARNING:** The Adjustable Section is not designed to bear vertical force loads. Appropriate supports must be provided.

Note: Vent diameters of 5" thru 16" have a double sealing gasket on the inside of the inner vent, **NO RTV** is needed.

Installation Procedure

The Adjustable assembly consists of 6 components, the female Inner Vent, the male Outer Vent, a Clamp, an alcohol pad, an outer Coupler Band and a packet of silicone lubricant (5" - 16" diameters only).

Step 1: Disassemble the packaged vent.

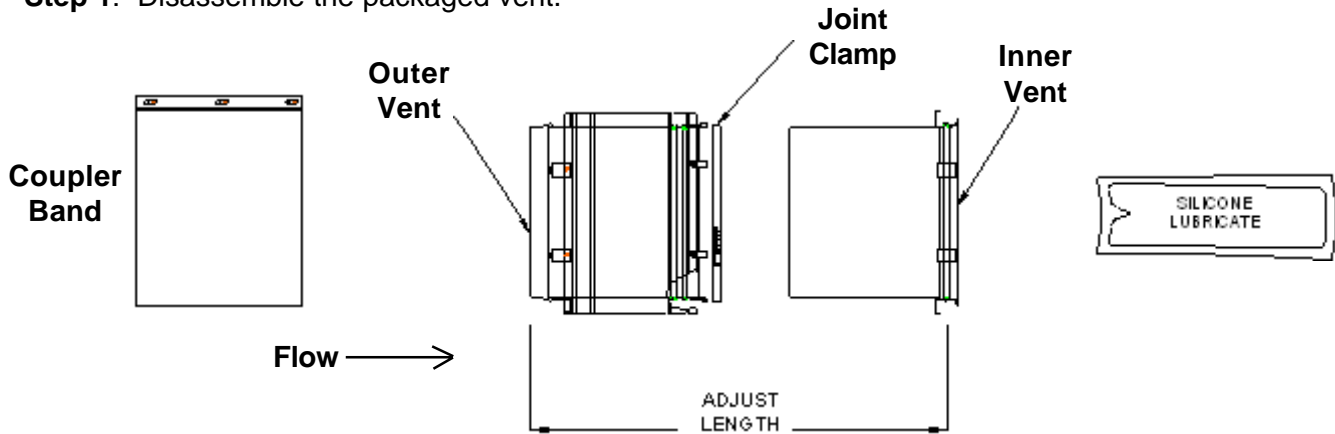

Step 2: Measure edge to edge the distance needed, then add 3 inches total for the joints. The installed length is 13 to 20 inches for the long adjustable section and 7 to 11 inches for the short adjustable section.

CAUTION: DO NOT LENGTHEN PAST THE WARNING ARROW.

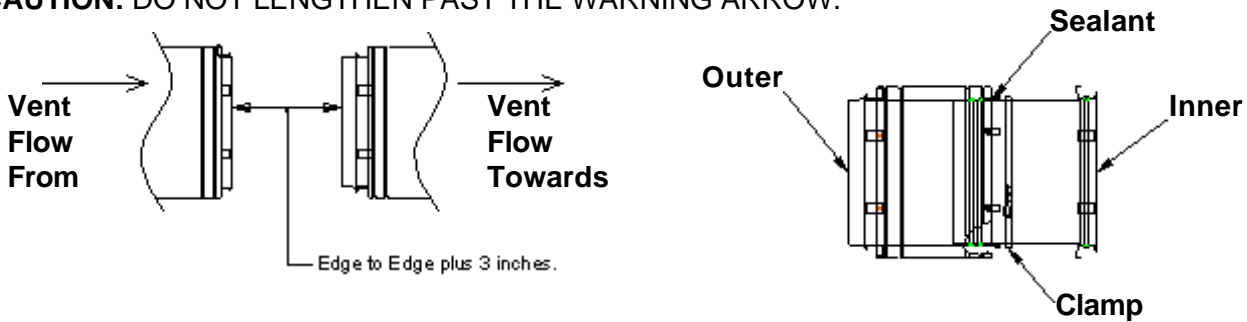

Step 3: Gasketed: Lightly apply the silicone lubricant to the upper ridges of both gaskets in the outer vent. Slide the Inner Vent into the Outer Vent to the desired overall length. **Non-Gasketed:** Slide the Inner Vent into the Outer Vent to the desired overall length. Apply a 1/4" bead of RTV sealant into the crevice, completely around the vent. Smooth sealant into place.

Step 4: When the adjustable section is at its desired length, tighten the wormgear clamp securely around the vent to hold the adjustable in place. Do not over tighten, as it may distort the joint.

Step 5: Install the completed Adjustable Section per the Joint Assembly instructions. After installation check the integrity of the RTV sealed crevice prior to attaching the Coupler Band over the completed Assembly.

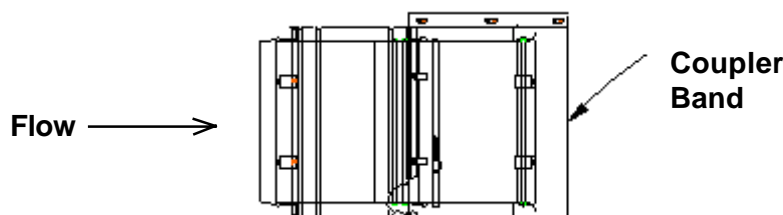

Saf-T Vent CI Plus Horizontal Support For Large Diameters:

Saf-T Vent CI Plus must have supports for every six (6) feet of horizontal run and after every transition from vertical to horizontal. For large diameters, 24"-32" use parts numbered CCM24HZZS - CCM32HZZS. The support may be attached from the center bracket, figure 1 or attached to the side brackets, figure 2. Support hangers by themselves do not maintain the necessary clearances to combustible materials; be sure to consider clearances when planning the system. For 5" thru 24" diameters use support clamp part number 4627SS-42627SS and attach as appropriate.

LARGE DIAMETER SUPPORTS

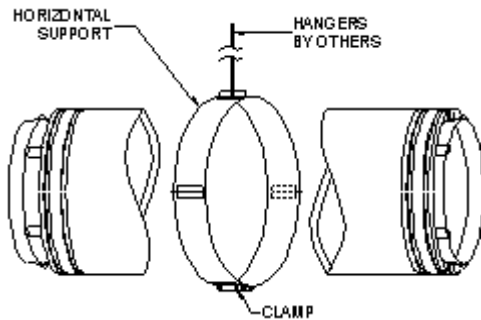

Figure 1

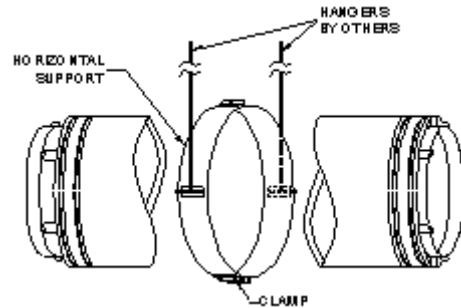
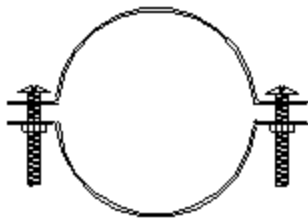

Figure 2

5" - 24" DIAMETER SUPPORTS



Support Clamp

Used in pairs to clamp around the vent and suspend from a single rod or cable.



Support Clamp

Used singularly as a saddle to rest the vent in; suspend from two rods or cables.

Saf-T Vent CI Plus Rain Cap:

1. Remove the Bolts from the Rain Cap's Storm Collar.
2. Place the Storm Collar over the last piece of stack vent.

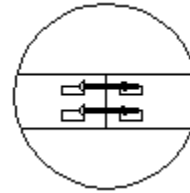

Bolts

Storm Collar

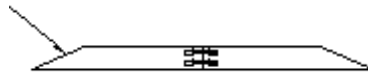

3. Install the Rain Cap on top of the last piece of stack per the Joint Assembly Instructions, except do not seal the joint with RTV sealant to permit removal of the Rain Cap for inspection of the system.

Rain Cap

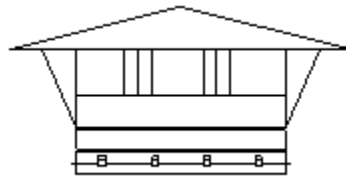

4. Raise the Storm Collar to just above the locking strap on Rain Cap.
5. Reinstall Collar bolts and tighten the Storm Collar around Rain Cap.
6. Apply RTV sealant around the top of Storm Collar.
7. When installing the Rain Cap with the Tall Cone Flashing, the Ventilation Collar **must** be ordered separately.

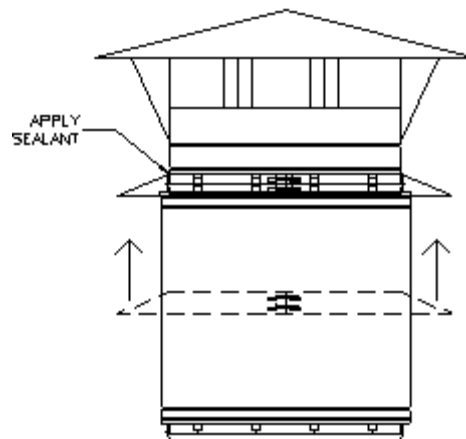

Saf-T Vent CI Plus Guy Support:

Guy Support Assembly:

Assemble the guy support to the vent sections as shown in the joint assembly instructions. Once the guy support is assembled to the vent sections, *figure 1*, install the 5" long coupler from the guy support so that it fits directly on top of the guy brackets. On the vent section below the guy support, attach the 8" long coupler so that it fits up to the bottom of the guy brackets, *figure 2*. The guy support is now totally enclosed with only the guy brackets protruding, *figure 3*, the guy lines can be attached before or after installation of the couplers.

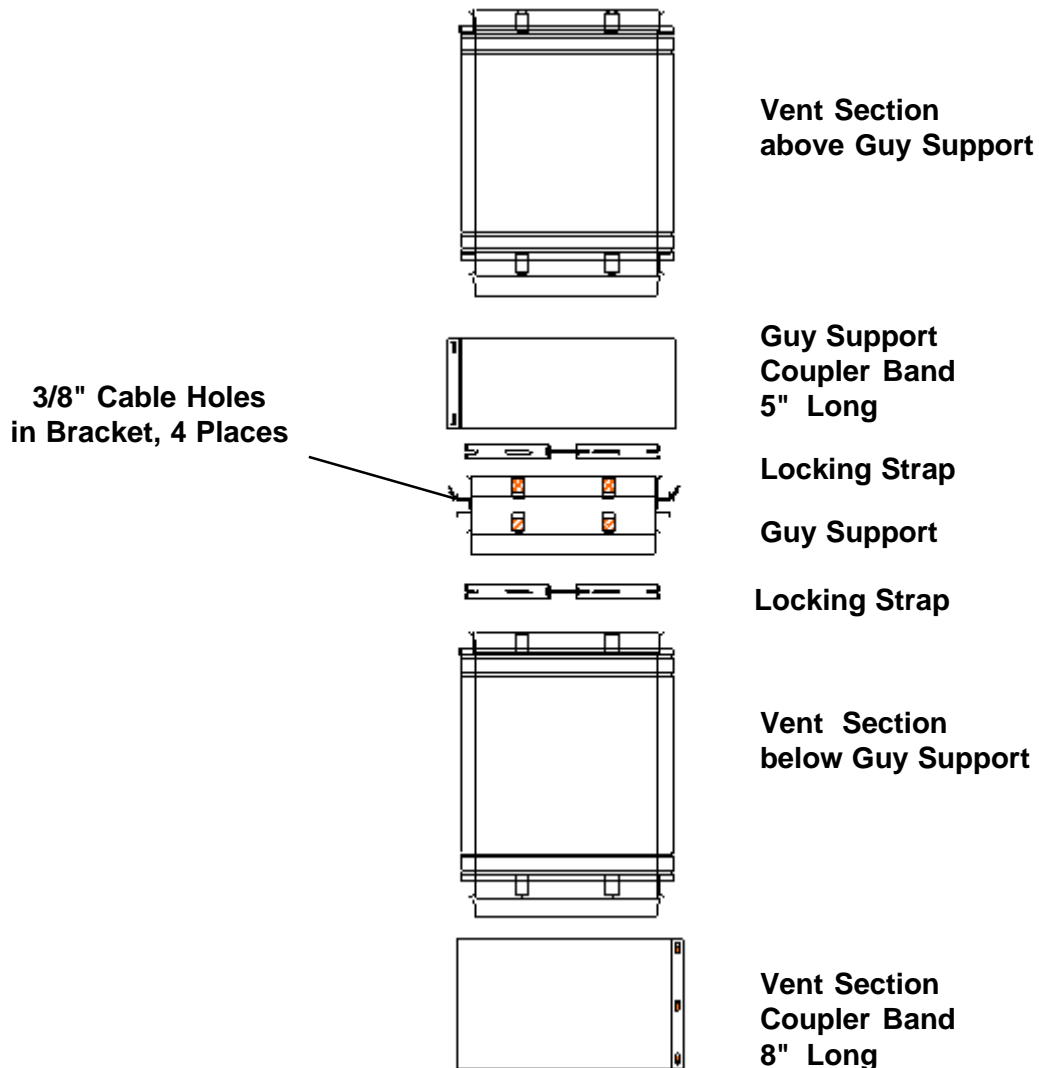

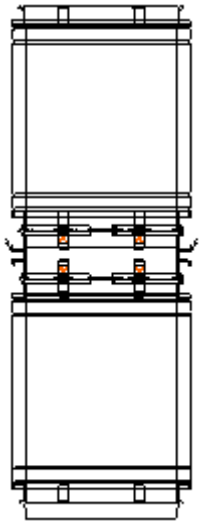

Figure 1

Guy Support assembled to Vent.

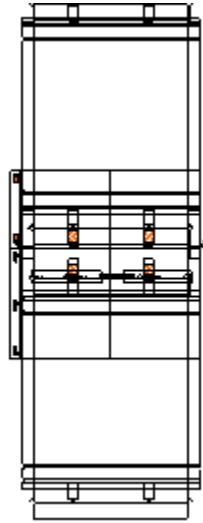

Figure 2

Guy Support Coupler attached above and Vent Section Coupler attached below.

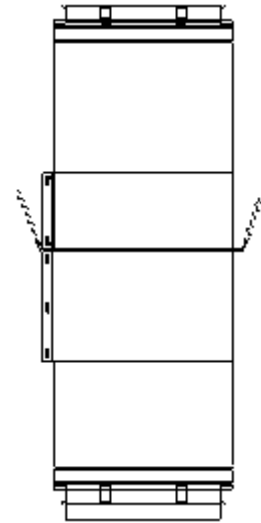

Figure 3

Guy Support Bracket for attaching Guy Lines.

Spacing Between Supports	
Diameters	Spacing
5" thru 12"	20'
14" thru 18"	12'
20" thru 24"	10'
26" thru 32"	6'

The Guy Supports can be used in five different applications:

- 1. To Lower a Stack Inside of a Chase**
- 2. To Support a Stack from Below a Floor or Roof**
- 3. To Support a Stack Above a Roof**
- 4. To Support a Stack Above a Floor**
- 5. To Support Horizontally**

APPLICATION 1. To Lower A Stack (Figure 4).

Attach guy wires or chains with a minimum rated capacity of 500 lbs. to the four hole locations on the guy bracket. Some lengths of stack may be assembled to go below the guy support. Feed the lengths and the guy support into the top of chase and add lengths as the stack is lowered into the chase. When lowering a stack in a square or rectangular chase, position the cable holes on the guy support in the corners of the chase. Anchor the guy lines to the top of chase utilizing the best construction methods.

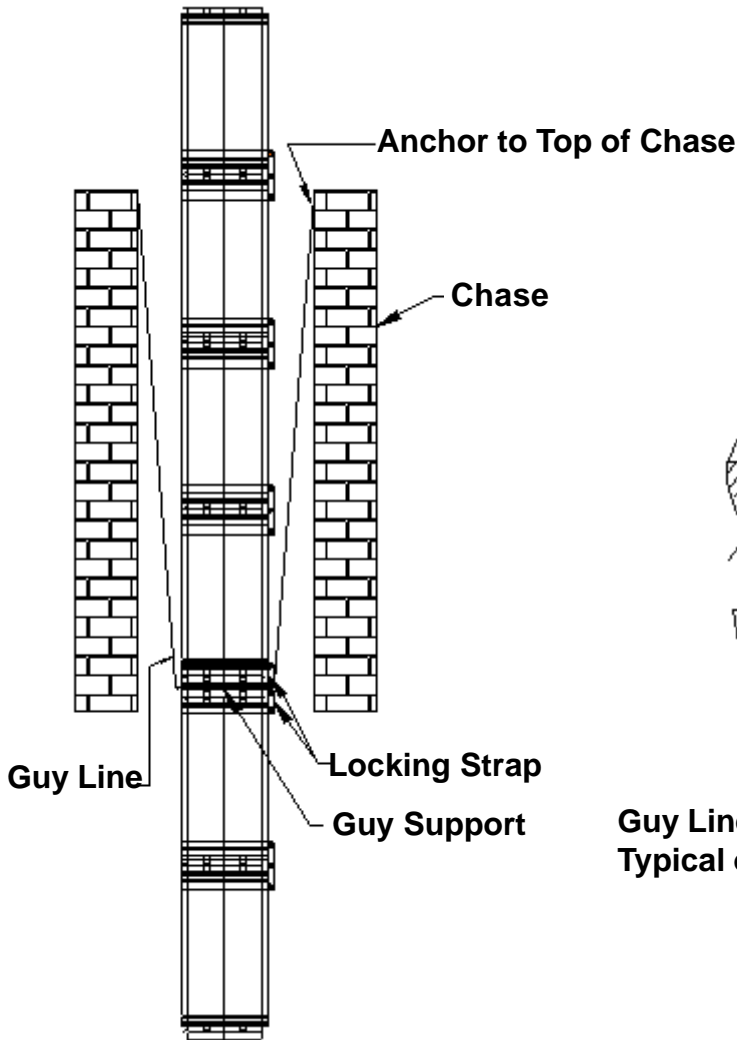

Figure 4

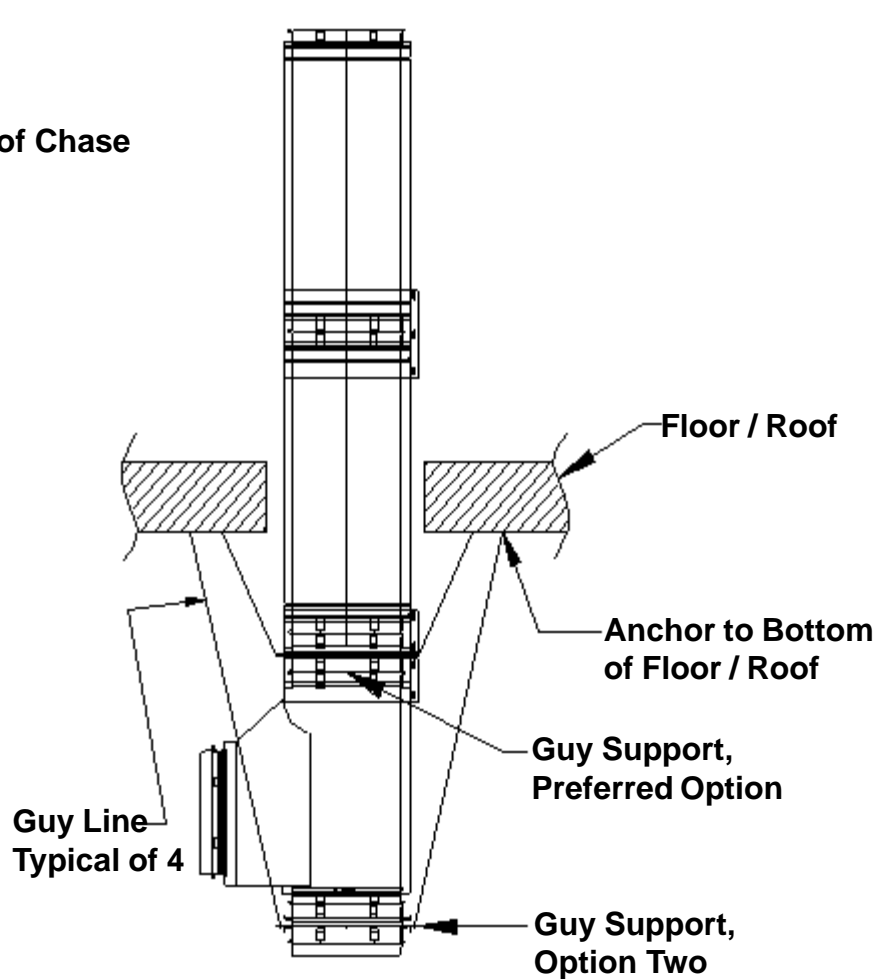

Figure 5

APPLICATION 2. Support Below a Floor or Roof (Figure 5).

Attach guy wires, chains, or threaded rod with a minimum rated capacity of 500 lbs. to the four hole locations on the support brackets. Anchor the guy lines to the building infrastructure on the underside of the floor or roof. Continue to attach vent lengths above and below the guy support.

Option One: Install the Guy Support above the Boot Tee (preferred).

Option Two: Install the Guy Support below the Boot Tee.

APPLICATION 3. **Support Above a Roof (Figure 6).**

Required if stack extends more than 6' above the roof.

Note: When using a guy support above a roof, the stack below the roof must be supported. Install the guy support between the last 2 sections of straight vent. Attach guy wires or chains, with a minimum rated capacity of 500 lbs, to the four hole locations on the guy brackets. Anchor the guy lines to the top of the chase or other structure utilizing best construction methods to stabilize the system.

Option One: Install the Guy Support above the Boot Tee (preferred).

Option Two: Install the Guy Support below The Boot Tee.

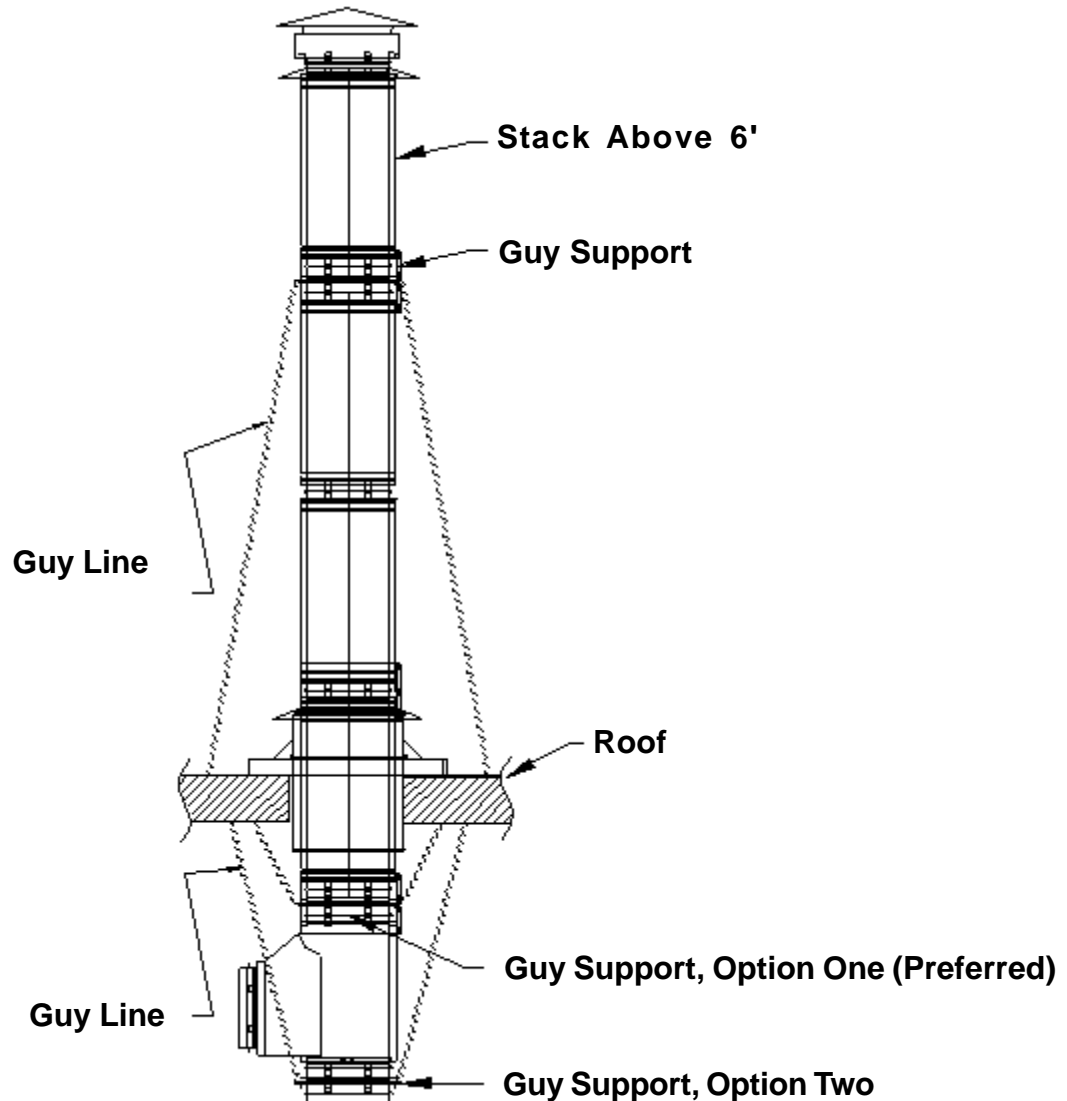
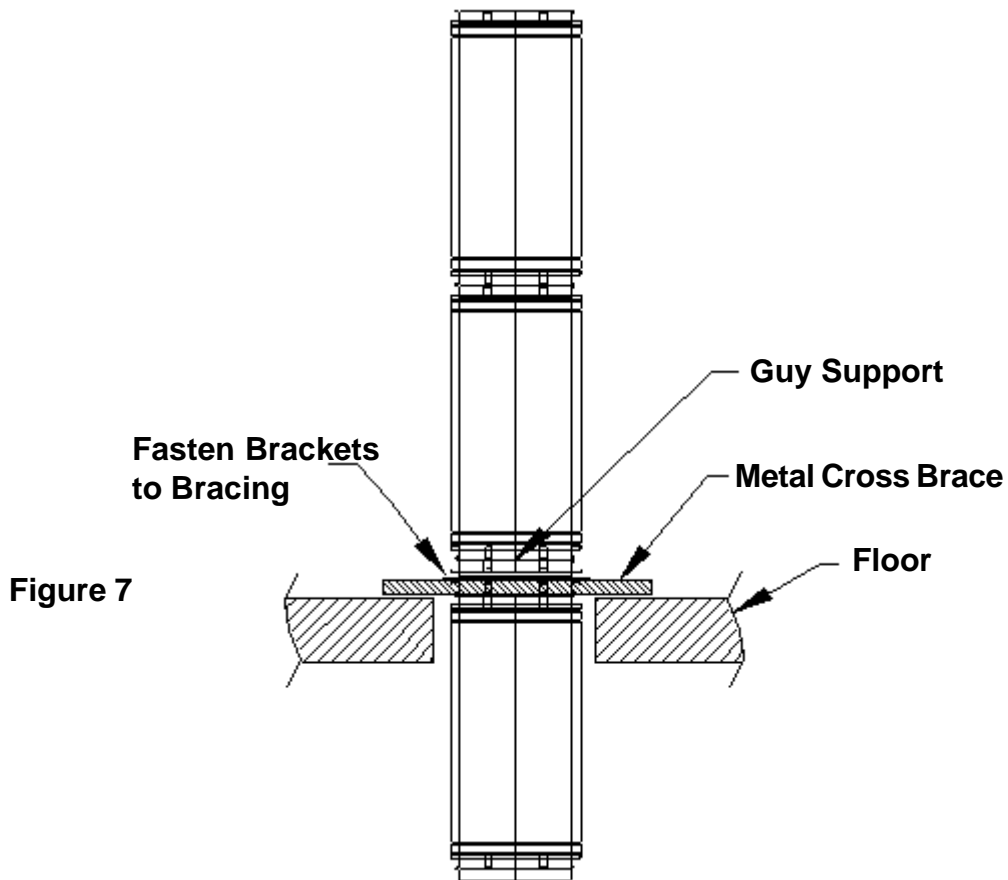

Figure 6

APPLICATION 4. Support Above a Floor (Figure 7).

The guy support may be set on lengths of metal bracing that are secured to the floor. Make sure that the guy brackets are positioned over the metal bracing. Drill through the metal bracing and secure with appropriate nuts and bolts. Do not completely tighten, to allow for expansion and contraction of the system.



APPLICATION 5. Support Horizontally (Figure 8).

Support horizontally by attaching guy wires, chains or threaded rod to the guy support bracket holes. Anchor the guy lines to the building infrastructure on the underside of the floor or roof.

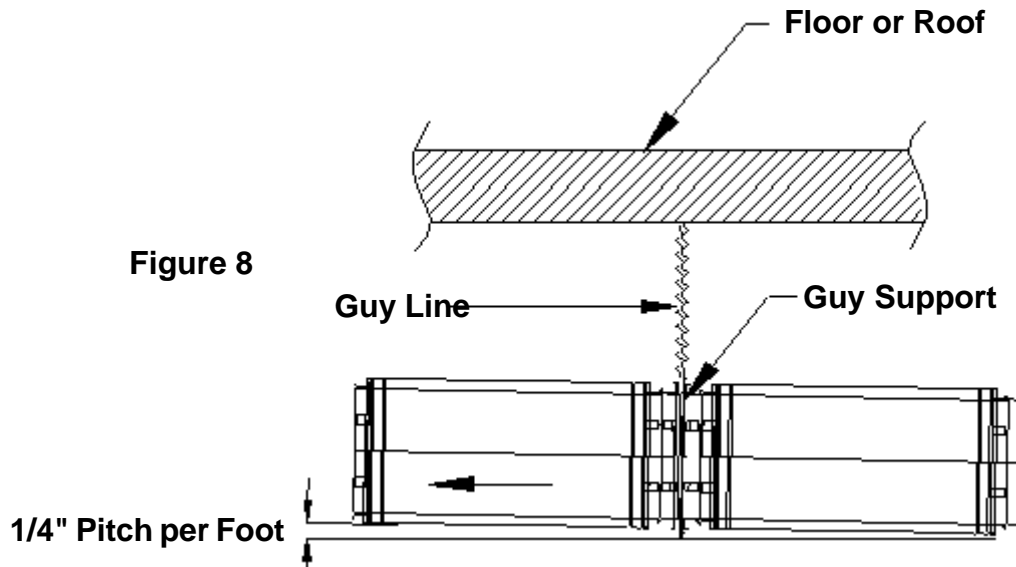

Saf-T Vent CI Plus Tall Cone Flashing with Rain Cap In Combustible Chase:

APPLICATION 1. *Directly On Flat Roof (figures 1 & 2).*

Prepare a square or round opening 4 1/2" larger than the inner vent pipe diameter, i.e. an 8" inner vent would have a 12 1/2" opening. Apply weather-stripping or outdoor caulk to the bottom of the cone plate. Attach the cone to the roof using common construction methods. Flash over the cone plate and seal the fastener heads using normal roofing requirements. When the vent pipe is in place through the Tall Cone, attach the Tall Cone storm collar around the pipe and position at least 2" above the top edge of the cone (figure 1). This 2" air space will release any built up heat from inside the cone. Apply RTV sealant around the top of the storm collar and the pipe. On the last section of pipe before the Rain Cap, install the Ventilation Collar over the air space between the inner and outer vent pipes. Install the Rain Cap on the last section of vent per the Rain Cap installation instructions. Position the Rain Cap Storm Collar 2" above the Ventilation Collar as shown in Figures 1 & 3. When the Tall Cone is used as a vertical support, screw the self-tapping screws through the holes in the cone and into the wall of the Outer Vent.

CAUTION: Support screws can *only* be installed with Saf-T Vent CI Plus venting.

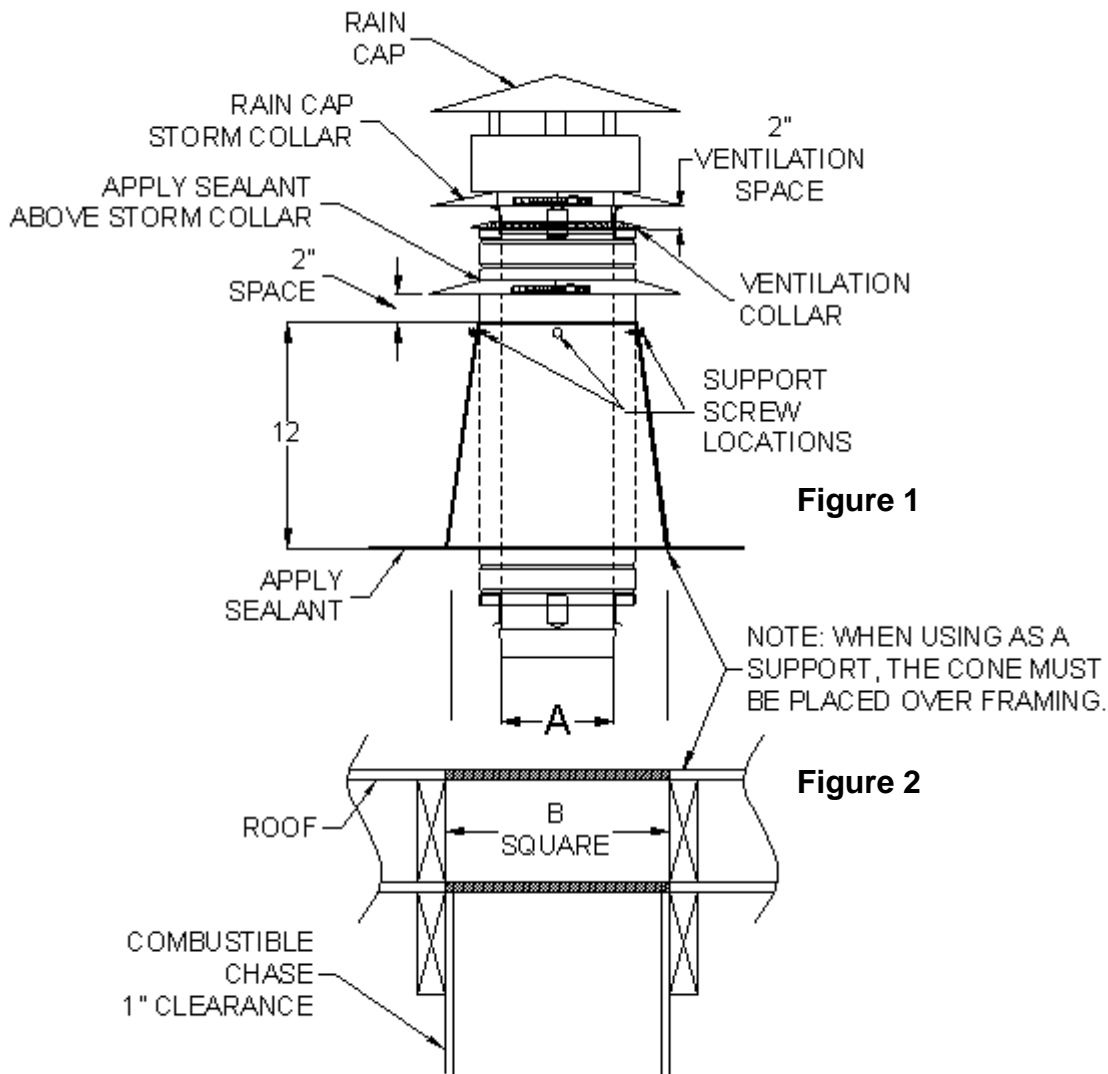

Roof Opening Framing Dimensions (figure 2):

ROOF OPENING FRAMING DIMENSIONS (FIG 1 & 2)			
CONE PART NUMBER	INNER VENT DIAM A	OUTER OPENING DIM B	SPACING BETWEEN VERTICAL SUPPORTS (FIG 2)
CCM05TCF	5	9.5	20
CCM06TCF	6	10.5	20
CCM07TCF	7	11.5	20
CCM08TCF	8	12.5	20
CCM09TCF	9	13.5	20
CCM10TCF	10	14.5	20
CCM12TCF	12	16.5	20
CCM14TCF	14	18.5	12
CCM16TCF	16	20.5	12
CCM18TCF	18	22.5	12
CCM20TCF	20	24.5	10
CCM22TCF	22	26.5	10
CCM24TCF	24	28.5	10
CCM26TCF	26	30.5	6
CCM28TCF	28	32.5	6
CCM30TCF	30	34.5	6
CCM32TCF	32	36.5	6

APPLICATION 2. On Top Of Roof Curb (figure 3).

Before installing, place the cone on top of the curb and mark the outline of the curb on the bottom of the cone plate. Use snips to notch out the corners of the plate to match the curb. Bend down the extra material with duckbill pliers to create a cap which fits over the curb. Attach the cone to the curb using the same methods as described in Application 1.

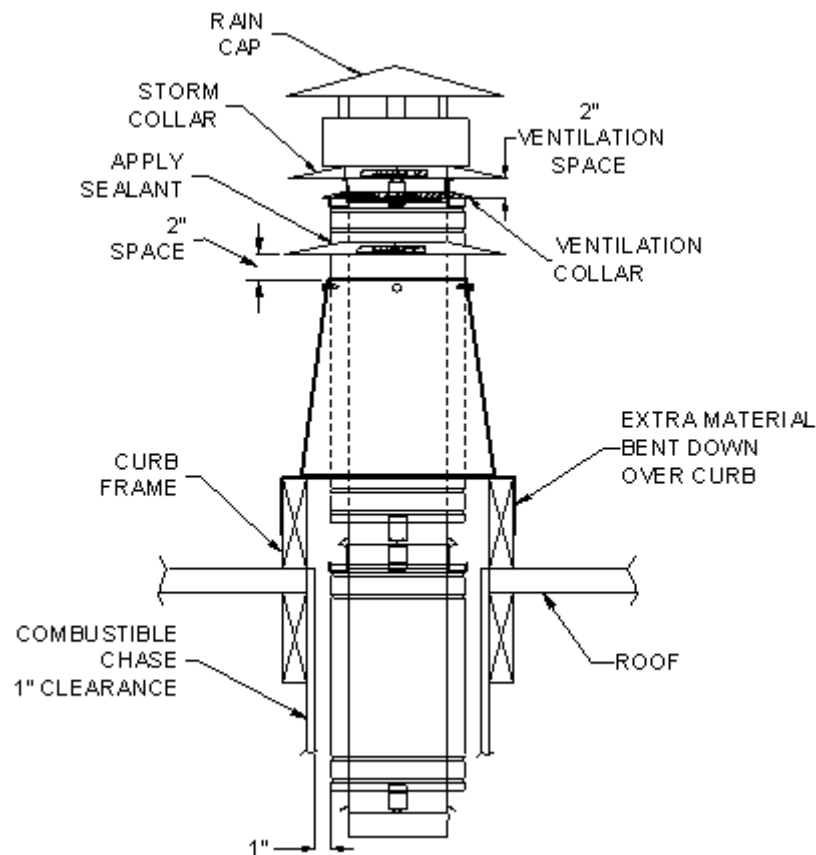
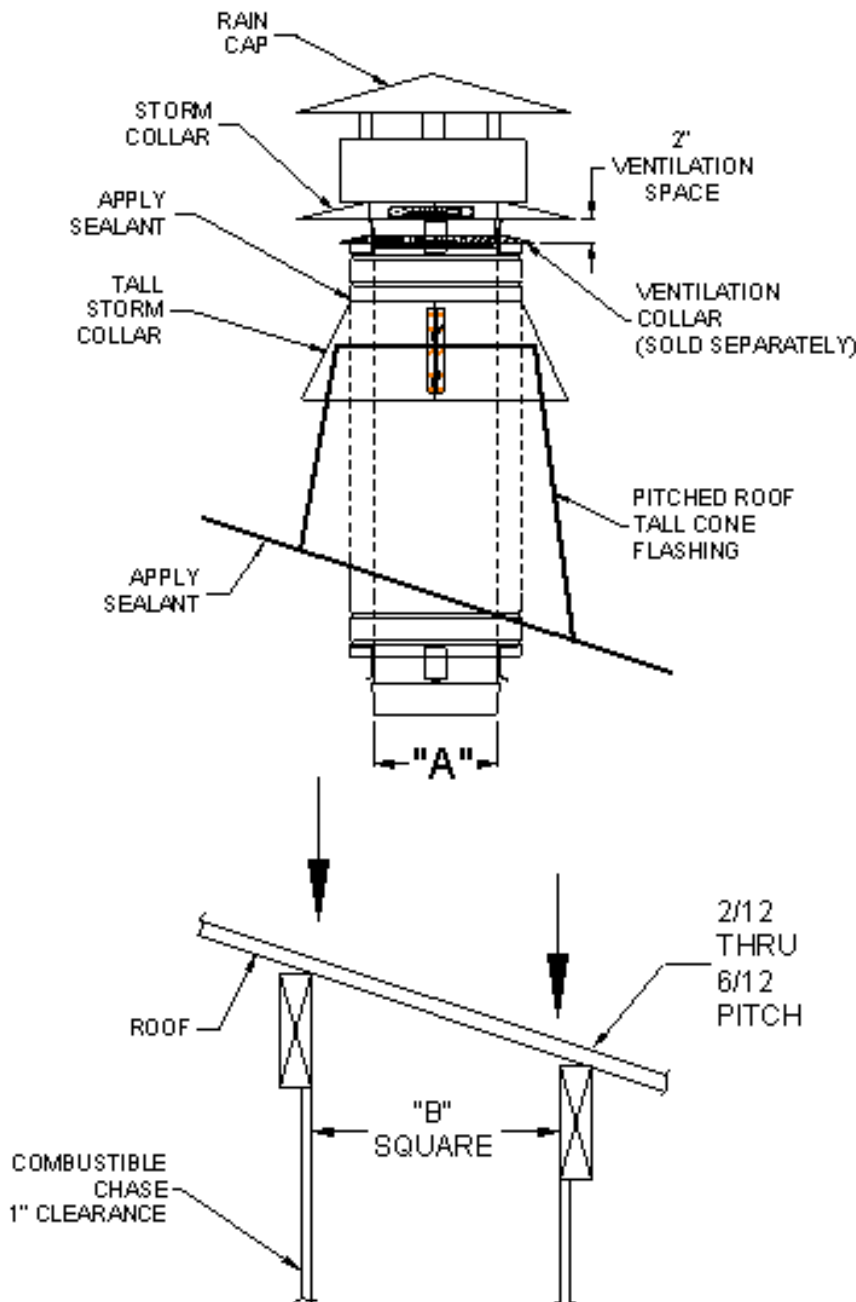

Figure 3

Saf-T Vent CI Plus Pitched Roof Tall Cone Flashing

Directly On Pitched Roof. Prepare a square or round opening per the framing chart. Apply weatherstripping or outdoor caulk to the bottom of the cone plate. Attach the cone to the roof using common construction methods. Flash over the cone plate and seal the fastener heads using normal roofing requirements. When the vent pipe is in place through the Tall Cone, attach the Tall Cone storm collar around the pipe. Apply RTV sealant around the top of the storm collar and the pipe. On the last section of pipe before the Rain Cap, install the Ventilation Collar, ordered separately, over the air space between the inner and outer vent pipes. Install the Rain Cap on the last section of vent per the Rain Cap installation instructions. Position the Rain Cap Storm Collar 2" above the Ventilation Collar as shown in the figure below.



ROOF OPENING FRAMING DIMENSIONS		
CONE PART NUMBER	VENT DIAM A	DIAM B
CCM05TCFP	5	9.5
CCM06TCFP	6	10.5
CCM07TCFP	7	11.5
CCM08TCFP	8	12.5
CCM09TCFP	9	13.5
CCM10TCFP	10	14.5
CCM12TCFP	12	16.5
CCM14TCFP	14	18.5
CCM16TCFP	16	20.5
CCM18TCFP	18	22.5
CCM20TCFP	20	24.5
CCM22TCFP	22	26.5
CCM24TCFP	24	28.5
CCM26TCFP	26	30.5
CCM28TCFP	28	32.5
CCM30TCFP	30	34.5
CCM32TCFP	32	36.5

Saf-T Vent CI Plus Wall Termination:

The Saf-T Vent CI Plus system can be installed through any type of wall using the Saf-T Vent CI Plus Wall Termination Assembly. The wall termination requires mechanical support from the wall sufficient to support any incidental loads on the system. If the wall is not constructed sufficiently enough to support the termination assembly, then appropriate additional framing and/or blocking is required.

1. The Wall Termination Assembly is packed with the screen cover and end collar (Figure 1). Before beginning, remove this screen cover. Prepare an opening for the Wall Termination Assembly in the wall. The opening must be 7 inches larger than the Inner Vent pipe diameter. The opening may be either round or square so long as allowance for proper clearance to combustible material is made. When passing through solid, noncombustible construction, clearances may be reduced if necessary. If there are not sufficient support members to secure the Wall Termination Assembly or if there is a semirigid foam insulation layer under the sheathing, the opening must be blocked out or framed to provide support.

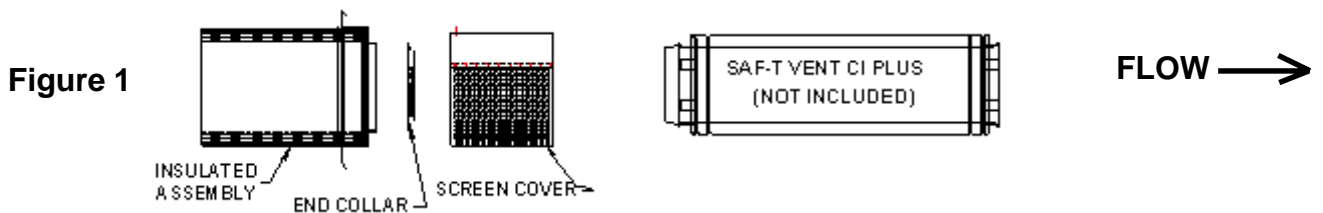

2. Position the Wall Termination Assembly into the enlarged hole from the outside (Figure 2). Secure the assembly using common construction methods. Seal under the screw heads with caulking. Reinstall the decorative sheathing around the Wall Termination Assembly. The assembly may be painted to match the exterior decor.

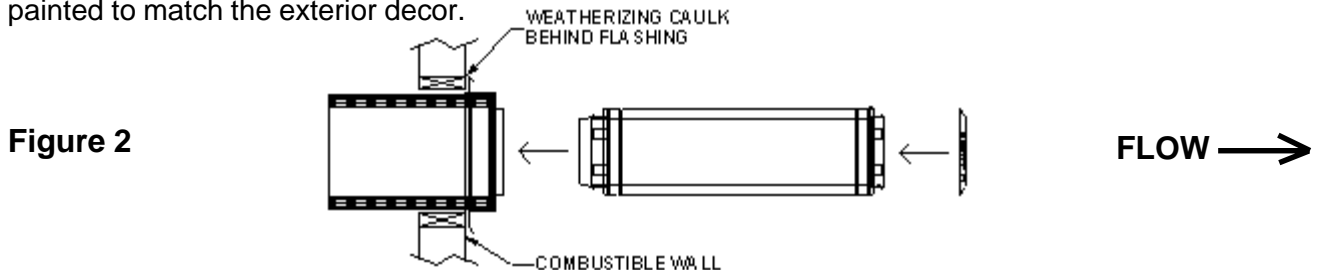

3. Proceed with the installation of Saf-T Vent CI Plus sections and terminate it through the Wall Termination Assembly (Figure 3). Install the End Collar on the last section to close off the 1" air space around the inner vent. Seal between the vent and the End Collar for weather conditions. The assembly is constructed to allow for 2 degrees (1/4" per foot) of pitch in the vent sections. Seal the gap between the vent and the end plate of the Assembly using silicone caulk suitable for extended exposure to the elements.

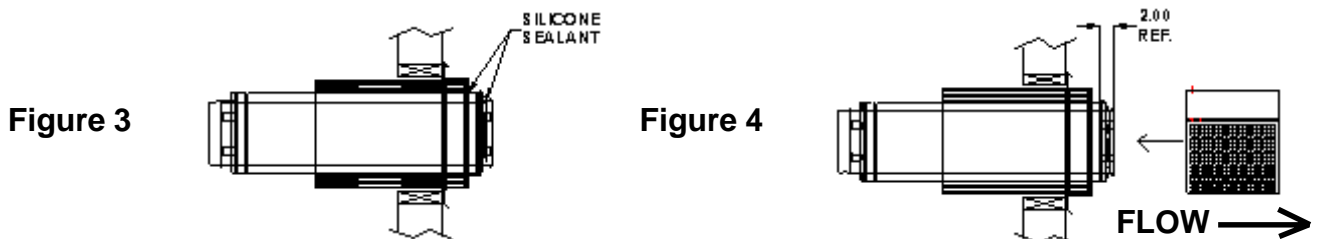

4. The vent section must protrude at least 2 inches into the screened area beyond the end plate of the Wall Termination Assembly (Figure 4). Attach the screen cover using stainless screws. Align the hole in the top (solid) portion of the screen cover with the top of the assembly and securely screw the two pieces together. The screen cover may be easily removed for inspection of the venting system.

Maintenance Procedures:

- Normal operation of gas burning appliances does not result in deposits of combustible soot in venting systems. However, a poorly adjusted or malfunctioning appliance can deposit soot and other debris which can enter the vent system. As with all vents, the Saf-T Vent CI Plus system should be inspected at least annually for the presence of deposits of soot or debris. Any such accumulation should be removed and the appliances adjusted to eliminate future accumulation.
- At regular periods the system should also be inspected for signs of leakage of condensate or combustion by-products at all joints. If any leakage is found the connected appliances should be turned off and the leaks repaired.
- If the system incorporates a drain hose from either an in-line fitting or from a drain tee then the hose must be inspected periodically to assure that water remains in the trap loop. If a proper trap loop is not maintained exhaust from the connected appliances may accumulate in the building area.

SAF-T VENT CI PLUS LIMITED WARRANTY

Heat-fab, Inc. warrants to the original consumer that the Saf-T Vent CI Plus shall be free from defects in material and manufacturer's workmanship when properly installed pursuant to the manufacturer's installation instructions and in accordance with national and local building codes. Any defect arising from the improper installation, operation, or maintenance of this system and/or connected appliance(s) is NOT covered by this warranty.

In order to obtain warranty service, the consumer must give prompt written notice of any defect to Heat-fab, Inc. within ten (10) years from the date of manufacture.

The sole responsibility of Heat-fab, Inc. shall be to replace those parts of Saf-T Vent CI Plus found to be defective upon authorized return F.O.B. to Heat-fab, Inc., 130 Industrial Blvd., Turners Falls, MA 01376.

Heat-fab, Inc. shall not be responsible for the cost of inspecting, removing, or reinstalling the parts subject hereto, nor shall it be liable for any special, incidental, or consequential damages or expenses incurred by the consumer or its contractors. The warranty on any replacement parts shall be for the unexpired term of the original warranty.

This warranty gives the consumer specific legal rights, in addition to any other rights which may pertain and may vary from state to state.

