

MATERIALS OF CONSTRUCTION

HEAT EXCHANGER:
SAND CAST ALUMINUM ALLOY
EN AC-AISI109(o), F Temper

HEAT EXCHANGER DESIGN STANDARDS

MAX. WORKING PRESS. (PSIG): 50
MAXIMUM TEMP. (°F): 200
TEST PRESS. (PSIG): 75
MIN. RELIEF VLV. CAPACITY (MBH): 1007

ASME B & PV CODE SECTION IV STAMP H

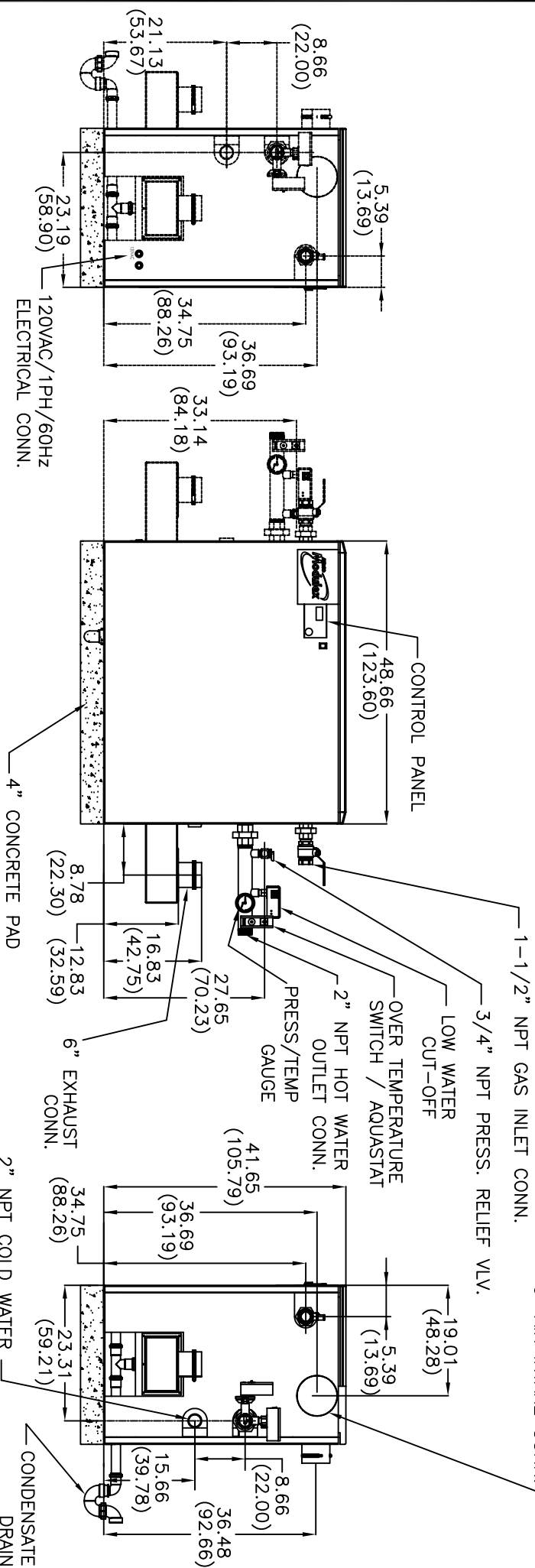
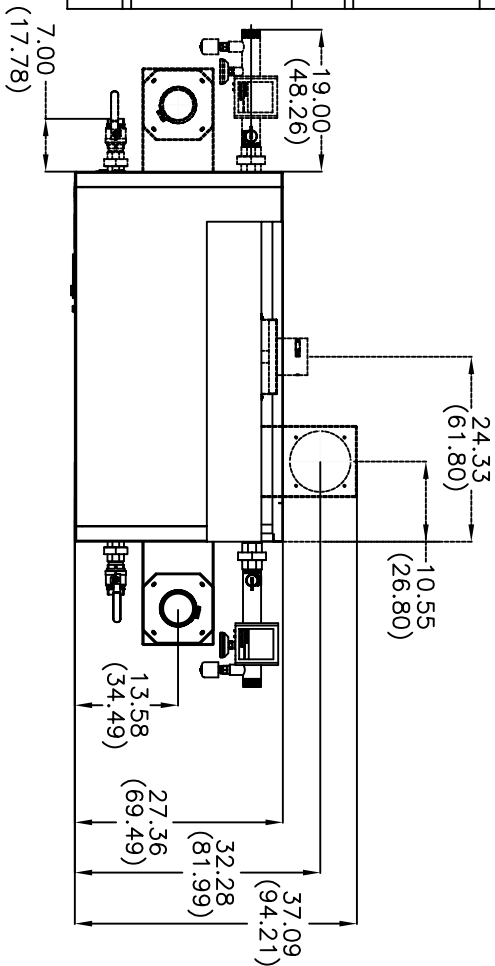

NOTES:

- 1) ALL DIMENSIONS SHOWN ARE IN INCHES (CENTIMETERS)
- 2) ALTERNATE LOCATIONS FOR COMPONENTS/CONNECTIONS ARE SHOWN IN DOTTED LINES.
- 3) WHEN USING ALTERNATE WATER CONNECTIONS, THE LEFT HAND AIR INTAKE CONNECTION CANNOT BE USED.
- 4) EXHAUST CONNECTION, AIR INTAKE CONNECTION, AND CONDENSATE TRAP ARE INCLUDED SEPARATELY IN SHIPMENT.
- 5) RELIEF VALVE, LOW WATER CUT-OFF, PRESS./TEMP GAUGE, AQUASTAT, AND THE 2" PIPE MANIFOLD FOR THESE COMPONENTS ARE INCLUDED SEPARATELY IN SHIPMENT.

AERCO INTERNATIONAL, INC.
NORTHVALE, NJ 07647

MODULEX MODEL MLX-1060
GAS FIRED BOILER
DIMENSIONAL DRAWING

DWN. BY C.Z. DATE 06/16/06
SCALE _____ SIZE A
CHKD. _____ APPD. _____
REV. DATE _____

AP-A-805

REV B