

MODEL SS1B+ / . / P

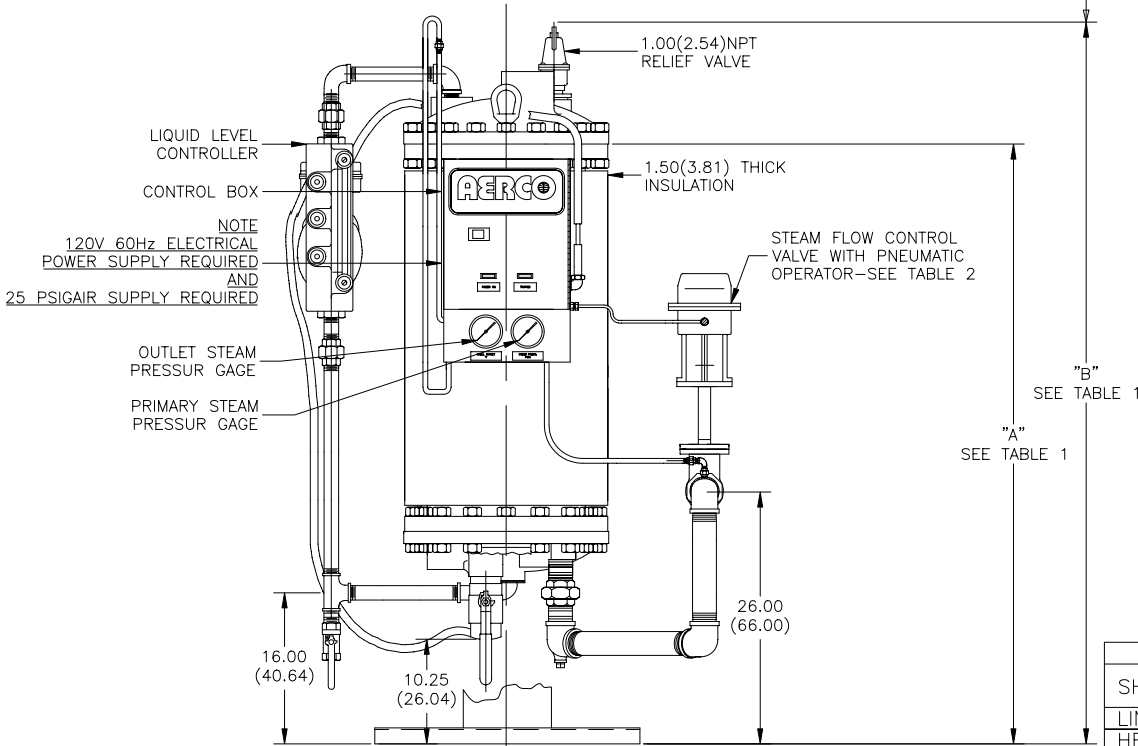

NOTE
120V 60Hz ELECTRICAL
POWER SUPPLY REQUIRED
AND
25 PSIG AIR SUPPLY REQUIRED

MATERIALS OF CONSTRUCTION	
SHELL	1/4"(0.64), 14"(35.56) DIAM., SA53 GRD(B)(ERW) CARB. ST.
LINER	COPPER, ASTM B-370 ALLOY 122
HEADS	BRONZE SB-62
COILS	COPPER, 0.049"(0.12) WALL, SB-111 ALLOY 122

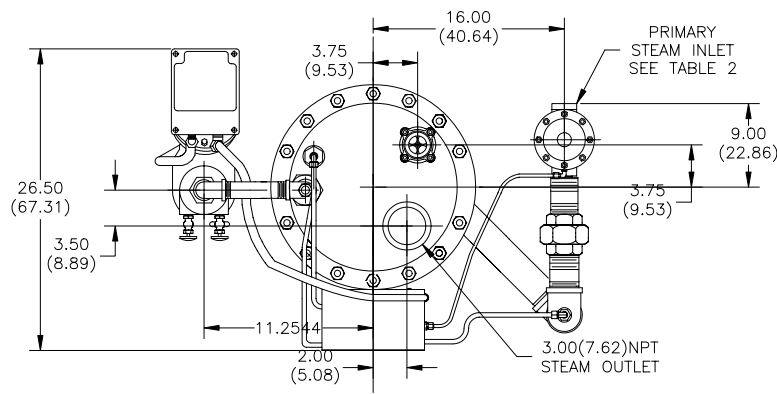
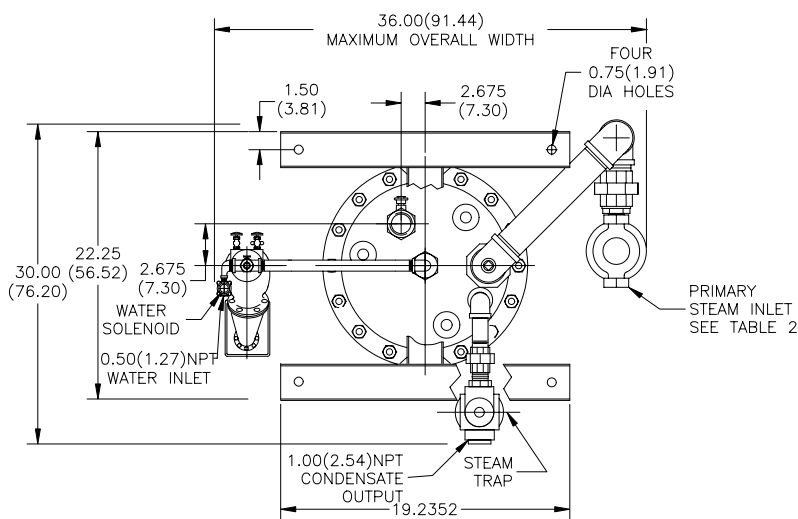

GENERATOR MODEL	NO. OF COILS	HEATING SURF. SQ.FT.(SQ.M.)	DIM. IN.(CM)			WT. LBS.(Kg.)	
			"A"	"B"	"C"	DRY	WET
SS1B+02	2	15 (1.39)	40.75 (103.5)	55.00 (139.70)	21.00 (53.34)	520 (237)	600 (300)
SS1B+03	3	15 (1.39)	45.75 (116.21)	60.00 (152.40)	26.00 (66.04)	570 (259)	720 (327)
SS1B+04	4	20 (1.85)	49.75 (126.37)	64.00 (162.56)	30.00 (76.20)	610 (277)	770 (350)
SS1B+05	5	25 (2.32)	54.75 (139.07)	55.00 (139.70)	35.00 (88.90)	640 (291)	830 (377)
SS1B+06	6	30 (2.78)	58.75 (149.23)	73.00 (185.42)	40.00 (101.60)	670 (304)	880 (400)
SS1B+07	7	35 (3.25)	63.75 (162.93)	78.00 (198.12)	45.00 (114.30)	710 (322)	930 (422)
SS1B+08	8	40 (3.71)	67.75 (172.09)	82.00 (208.28)	50.00 (127.00)	740 (336)	980 (445)
SS1B+09	9	45 (4.18)	72.75 (184.79)	87.00 (220.95)	55.00 (139.70)	770 (350)	1030 (468)
SS1B+10	10	50 (4.63)	76.75 (194.95)	91.00 (231.14)	60.00 (152.40)	800 (363)	1080 (490)
SS1B+11	11	55 (5.11)	81.75 (207.65)	96.00 (243.84)	65.00 (165.10)	840 (381)	1130 (513)
SS1B+12	12	60 (5.56)	85.75 (217.81)	100.0 (254.00)	70.00 (177.80)	870 (395)	1180 (536)
SS1B+13	13	65 (6.04)	90.75 (230.51)	105.0 (266.70)	75.00 (190.50)	900 (409)	1230 (558)
SS1B+14	14	70 (6.49)	94.75 (240.67)	109.0 (276.86)	80.00 (203.20)	930 (422)	1280 (581)
SS1B+15	15	75 (6.97)					

HEAT EXCHANGER DESIGN STANDARDS			
	MAX. WORKING PRESS. PSIG(KPa)	MAX. TEMP. °F(°C)	TEST PRESS. PSIG(KPa)
SHELL SIDE	90(620)	350(177)	135(931)
TUBE SIDE	250(1723)	400(204)	375(2584)
ASME CODE CERTIFICATION STAMP			U

PRESSURE RELIEF VALVE SET AT PSIG	
OPERATING CONDITIONS	
SHELL	CAPACITY, LB/HR (Kg/S) / PRESSURE PSIG (KPa)
TUBES	LB/HR (Kg/S) / PRESSURE PSIG (KPa)

AERCO INTERNATIONAL, INC.
NORTHVALE, NJ 07647

SS1B+
STEAM GENERATOR
DIMENSIONAL DRAWING

DWN. BY DMM DATE 08/15/01	REV. C
SCALE _____	AP-A-545
APPD. _____ DATE _____	